

DIVISION 26 – ELECTRICAL

Contents

26 05 00 GENERAL ELECTRICAL REQUIREMENTS.....	3
26 05 13.16 MEDIUM VOLTAGE CIRCUITS.....	10
26 05 19 LOW-VOLTAGE POWER CONDUCTORS AND CABLES.....	12
26 05 26 GROUNDING AND BONDING FOR ELECTRICAL SYSTEMS.....	14
26 05 29 HANGERS AND SUPPORTS FOR ELECTRICAL SYSTEMS.....	17
26 05 33 RACEWAY AND BOXES FOR ELECTRICAL SYSTEMS.....	18
26 05 36 CABLE TRAYS FOR ELECTRICAL SYSTEMS.....	20
26 05 43 UNDERGROUND DUCTS AND RACEWAYS FOR ELECTRICAL SYSTEMS.....	21
26 05 43.19 MANHOLES AND HARDWARE.....	24
26 05 53 ELECTRICAL SYSTEM IDENTIFICATION.....	26
26 05 73 ELECTRICAL STUDIES.....	28
26 08 00 ELECTRICAL COMMISSIONING.....	32
26 09 00 INSTRUMENTATION AND CONTROL FOR ELECTRICAL SYSTEMS.....	37
26 09 23 LIGHTING CONTROL DEVICES.....	39
26 11 16 UNIT SUBSTATIONS.....	41
26 12 16 DRY-TYPE MEDIUM VOLTAGE TRANSFORMERS.....	43
26 12 19 PAD-MOUNTED, LIQUID FILLED MEDIUM VOLTAGE TRANSFORMERS.....	45
26 13 16 MEDIUM VOLTAGE FUSIBLE INTERRUPTER SWITCHGEAR.....	47
26 18 16 MEDIUM VOLTAGE FUSES.....	51
26 22 00 LOW VOLTAGE TRANSFORMERS.....	52
26 24 13 SWITCHBOARDS.....	53
26 24 16.13 PANELBOARDS.....	57
26 24 19 MOTOR-CONTROL CENTERS.....	59
26 25 00 ENCLOSED BUS ASSEMBLIES.....	60
26 26 53 ELECTRIC VEHICLE CHARGING STATIONS.....	61
26 27 13 METERING.....	62
26 27 26 WIRING DEVICES.....	65
26 28 16 ENCLOSED SWITCHES AND CIRCUIT BREAKERS.....	67

26 29 13	ENCLOSED CONTROLLERS	68
26 29 23	VARIABLE FREQUENCY MOTOR CONTROLLERS.....	69
26 31 00	PHOTOVOLTAIC COLLECTORS (SOLAR PANELS)	71
26 32 13	ENGINE GENERATORS	73
26 33 53	STATIC UNINTERRUPTIBLE POWER SUPPLY	78
26 36 23	AUTOMATIC TRANSFER SWITCHES	81
26 41 00	FACILITY LIGHTNING PROTECTION.....	83
26 43 13	SURGE PROTECTIVE DEVICE (SPD).....	84
26 50 00	INTERIOR LIGHTING.....	85
26 52 00	EMERGENCY LIGHTING.....	90
26 53 00	EXIT SIGNS	91
26 55 00	SPECIAL PURPOSE LIGHTING	92
26 56 00	EXTERIOR LIGHTING	93
APPENDIX A – GUIDELINES FOR REMODELS IMPACTING EXISTING EMERGENCY GENERATORS.....		95
DIVISION 26 – LIST OF FIGURES		99

26 05 00 GENERAL ELECTRICAL REQUIREMENTS

1. A/E General Electrical Design Requirements

- 1.1. All building service main switchboards shall be a main-tie-main configuration. Exceptions to this must be reviewed and approved by University engineering staff.
- 1.2. The basis of design for all building emergency systems shall be an emergency generator.
 - 1.2.A. **PROHIBITED:** Battery backed up egress lighting or exit signs, either individual lights or central inverter systems, without approval of Energy Management.
 - 1.2.B. **PROHIBITED:** Use of a second utility source for emergency or legally required standby power.
 - 1.2.B.1. Use of a second utility source to increase the reliability of non-legally required loads must be approved by Energy Management.
- 1.3. Design a coordinated overcurrent protective device system to minimize the possibility of power outages to critical building facilities.
 - 1.3.A. Reference 26 05 73 for coordination requirements.
- 1.4. Where ground fault protection is required, design a coordinated ground fault protection system to minimize the possibility of power outages to critical building facilities.
 - 1.4.A. There shall be a minimum of two (2) levels of ground fault protection at the service entrance equipment.
 - 1.4.B. Both levels of ground fault protections shall fully coordinate with a typical 30A branch circuit breaker.
 - 1.4.C. Additional ground fault protection may be required to provide personnel protection.
- 1.5. Equipment that meets the NEC requirements for arc flash mitigation or is at risk of high arc-flash or explosive conditions shall be specified with means to reduce or remove the arc-flash exposure.
 - 1.5.A. Reference 26 05 73 for arc flash hazard study requirements and acceptable methods of arc flash hazard mitigation.
- 1.6. Grounding systems shall not be specified solely by conformance with the NEC. The systems shall be fully designed, specified and shown on the drawings. Include a grounding riser diagram on the drawings and specify ground resistance.
- 1.7. Provide a ground grid under all electric vaults.
 - 1.7.A. Reference 26 05 26 for ground grid requirements.

- 1.8. All 13.8 kV cable, splicing and terminations from the manhole to the 15 kV service equipment shall be installed by the University Electric Utilities and shall be noted as such in the contract documents.
- 1.9. Locate electrical distribution equipment (600V and less) in dedicated electrical closets, electric rooms, or mechanical equipment rooms.
 - 1.9.A. Exclude piping, ductwork and other systems that are not compatible with the electrical installation from the entire interior of electrical closets, rooms and vaults from floor to structure.
 - 1.9.B. **PROHIBITED:** Panelboards located in corridors, hallways, classrooms and public spaces.
- 1.10. All gypsum board located inside electrical closets or rooms must be painted.
- 1.11. Electrical work in architecturally finished spaces shall be concealed. If concealment is not possible, electrical work shall be installed in a University approved surface raceway system.
- 1.12. Provide a nominal 3-1/2-inch-high concrete housekeeping pad for floor mounted equipment.
 - 1.12.A. Pads shall extend horizontally 2 inches beyond the equipment footprint and shall be sealed before equipment is set on them.
- 1.13. Equipment and material shall be listed by a nationally recognized (e.g. Underwriters Laboratory) listing agency.
- 1.14. The design shall comply with Minnesota Energy Code, and in some cases the Minnesota B3 sustainable building guidelines. Consult with the University for Minnesota B3 requirements.
- 1.15. Remodels / Alterations, as defined by the Minnesota Conservation Code for Existing Buildings shall comply with the following:
 - 1.15.A. Level 1
 - 1.15.A.1. Only devices directly impacted by the remodel must comply with current University standards.
 - 1.15.B. Level 2
 - 1.15.B.1. All devices directly impacted by the remodel must comply with current University standards.
 - 1.15.B.2. If project area exceeds 50% of any floor - Panelboards with more than 50% of branch circuits supplying the project area shall be evaluated by A/E. Panelboards found to be deficient or at end of useful life shall be replaced.
 - 1.15.C. Level 3
 - 1.15.C.1. All devices directly impacted by the remodel must comply with current University standards.

- 1.15.C.2. Panelboards with more than 50% of branch circuits supplying the project area shall be evaluated. Panelboards found to be deficient or at end of useful life shall be replaced.
- 1.16. Project utilizing the Minnesota Building Code shall comply with Level 3 requirements if the project work area exceeds 50% of any floor or Level 2 requirements if the project work area is less than 50% of any floor.
- 1.17. All electrical conducting material shall be copper, unless specifically allowed otherwise in this document.
- 1.18. The phase arrangement on three-phase equipment shall be A-B-C from left to right, top to bottom, front to back, as viewed from the front of the equipment.
- 1.19. **PROHIBITED:**
- 1.19.A. Abandoning existing electrical circuits in place. Conductors must be pulled back to point of origin. The conduit can be left in place.
- 1.19.B. Direct buried underground wiring.
- 1.19.C. Power distribution cables in open raceways or cable trays, except for medium voltage cables in vaults.
- 1.19.D. Overhead power distribution wiring.
- 1.19.E. Drip pans on new installations.
- 1.19.F. Installing transformers or disconnect switches above accessible ceiling spaces.
- 1.20. FIRE PUMPS: Reference Division 21 construction standards for additional fire pump requirements.
- 2. A/E High Voltage Vault Design**
- 2.1. Reference Division 13 00 60 for high voltage vault design requirements.
- 3. A/E Electrical Drawings**
- 3.1. Schematic Design**
- 3.1.A. For new facilities, provide a power distribution one-line diagram (not to be confused with a riser diagram) from the service primary switchgear through the distribution panelboards and major loads.
- 3.1.A.1. For existing facilities that are being modified, update the University's existing building one-line diagram. Contact FM Records department for the latest one-line diagram.
- 3.1.B. Include the following in the one-line diagram:
- 3.1.B.1. Connection point to University 13.8 kV distribution system (typically in a manhole).

- 3.1.B.2. Ratings and sizes for MV Cable, Medium and low voltage buses, Motors (>10 hp), Switchboards, Distribution panels, Disconnects (> 60 amps), Transformers, and Breakers for switchboards and Distribution panels.
- 3.1.B.3. Metering and instrument transformers (CT's and PT's).
- 3.1.B.4. Kirk-key interlock system for main-tie-main systems.
- 3.1.B.5. Spares and spaces for breakers/switches.
- 3.1.B.6. Surge Protective Device (Medium and low voltage)
- 3.1.B.7. Breaker functions (LSIG)
- 3.1.B.8. Breaker maintenance switch (where applicable)
- 3.1.C. Submit a calculation of how the medium voltage power transformer sizing was developed.

The intent is to avoid defaulting to the largest transformer allowed which are expensive and waste energy. Main building transformers are typically grossly oversized at the schematic level and never get reduced from there.

- 3.1.D. Description of major systems (power, lighting, grounding, voice, data, fire alarm, emergency, special systems).
- 3.1.E. Include provisions for 20 percent future capacity at building completion. This includes spare devices and space requirements. Use of spares for building controls, etc. is not acceptable. This includes switchboards, panelboards, fire alarm panels, lighting control, and other similar equipment.
- 3.1.F. Include consideration for arc-flash hazards and identify how arc-flash will be mitigated in high risk areas.
 - 3.1.F.1. Reference 26 05 73 for arc flash hazard study requirements.

High risk areas include, but are not limited to: Line side of service disconnects, fire pumps/controllers, where the available fault current is less than 10 times the overcurrent protective device rating.

- 3.1.G. Site plan showing connection to utility systems (duct bank and manholes).
 - 3.1.G.1. Include site lighting description or preliminary layout.

- 3.1.G.2. Obtain identification numbers for medium voltage manholes, hand holes and pull boxes from the University electrical engineering staff. These numbers shall be shown on the design drawings.
- 3.1.G.3. Perform cable pulling calculations for each duct bank run to determine the pulling tension and sidewall pressure are within applicable limits for general applications. Calculations shall be submitted for review to the University electrical engineering staff, and shall be included in the project O&M manuals. If calculations indicate restrictions on the direction of the pull or location of the feed points, these restrictions shall be included in the contract documents.

3.2. Design Development

- 3.2.A. Refined site plan of pedestrian lighting, emergency egress lighting, and electrical utility systems, including a profile drawing of underground duct bank (may be shown in civil engineering plans).
- 3.2.B. Refinement to one-line diagram (including both winter and summer peak demands).
 - 3.2.B.1. Include short circuit ratings.
- 3.2.C. Perform and submit preliminary short circuit and arc flash calculations throughout the system.
 - 3.2.C.1. Reference section 26 05 73 for the requirements of each study.
- 3.2.D. Perform and submit a preliminary overcurrent coordination study of both the normal and emergency systems.
 - 3.2.D.1. Reference section 26 05 73 for the requirements of this study.
- 3.2.E. Specify means for arc flash hazard reduction, where required.
 - 3.2.E.1. Reference 26 05 73 for acceptable arc flash hazard mitigation options.

Arc-resistant equipment, remote breaker operators/control switches, maintenance switches, breaker remote racking devices, and integral arc detection systems are some of the acceptable options.

- 3.2.F. Layout electrical spaces including equipment shown on the one-line diagram. In addition, show fire system, building automation, security, SCADA panels and other panels that will require space in the electric rooms.
- 3.2.G. Floor plans showing every device.
- 3.2.H. Show access paths for major electrical equipment to and from the building.

- 3.2.I. Electric Vaults: Provide a plan and detailed elevation views for each vault. At a minimum, provide detail (to scale) for the following: Equipment plan and elevation outlines, concrete equipment pads, medium voltage raceways and pull boxes, ground buses and secondary busways.
- 3.2.J. Fire detection system plans.
- 3.2.K. Telecom-voice/data plans.
- 3.2.L. Schedules (motor, panelboards, lighting, etc.).
- 3.2.M. Electrical details.
- 3.2.N. Grounding riser diagram.
- 3.2.O. Ground grid design and calculations.

4. Service Interruptions and Energization

- 4.1. Service interruptions and energization of the University 13.8 kV system must be scheduled and coordinated with the University electrical engineering staff and the University Electric Utilities. Interruptions and energizing of the 13.8 kV system is treated with the highest level of safety, concern and care to avoid unintended interruptions to other facilities on the same 13.8 kV circuit or damage to other connected equipment.
- 4.2. Electric service to the project shall not be energized until the electric service facilities of the building are substantially complete (Refer to Section 260800 Electrical Commissioning for further detail on substantial completion).
- 4.3. The Division 26 contractor shall submit a written Utility Interruption Form to the University project manager, to the University electrical engineering staff, and to the University Electric Utilities general foreman.
 - 4.3.A. Submit the form a minimum of 14 days in advance of the required interruption or energization.

This notice is required to write a switching procedure, schedule a switching crew and isolate other facilities on the circuit(s) that may be impacted by the procedure.

- 4.4. The University Electric Utility department will operate and is in control of all 15 kV switches and circuit breakers. Initial energization of the primary transformers will be by the University Electric Utilities. Energization will be up to the primary transformer secondary disconnect device. The Division 26 contractor shall be responsible for operation of the main disconnect and energization of the main service switchboard, including all switchboard feeder breakers.

4.5. Following initial energization, only University Electric Utilities shall be in control of all equipment inside the **high** voltage vault.

5. Temporary Construction Power:

5.1. All temporary construction projects shall separately meter construction power use.

5.1.A. The project contractor shall provide an appropriate meter socket. The University shall provide a compatible socket meter.

5.1.B. Exception: Where the project area is less than 25% of the total building area, and construction power use will not significantly affect total building electrical use, separate construction electric metering is not required.

Building occupants are typically billed for building electric use. To minimize the financial impact of larger projects on building occupants, temporary construction power for these projects must be separately metered. This requirement is not intended to require separate metering for 'patch and paint' projects or projects which will have a negligible impact on total building electric usage.

5.2. Temporary construction power shall not be supplied from buildings outside the project area.

This is intended to minimize the risk of projects impacting occupants of neighboring buildings or buildings outside the project area. Power quality issues due to welder operation or faults in construction power circuits may impair sensitive equipment.

END OF SECTION

26 05 13.16 MEDIUM VOLTAGE CIRCUITS

1. General Cable Construction

- 1.1. For cable in duct banks, the construction shall consist of 105 degrees C, UL Type MV-105, 15 kV, 100% (175 mils) of ethylene propylene rubber (EPR) insulation, a copper tape shield, low smoke zero halogen jacket (per UL 1581 and UL 1685), and comply with ICEA Standard S-68-516.
- 1.2. For cable inside the building, the construction shall consist of 105 degrees C, UL Type MV-105, 15 kV, 100% (175 mils) or 133% (220 mils) of ethylene propylene rubber (EPR) insulation, a copper tape shield, low smoke zero halogen jacket (per UL 1581 and UL 1685), and comply with ICEA Standard S-68-516.
- 1.3. Conductors shall be compact copper.
- 1.4. The University standard sizes of 15 kV cable are: 500 kcmil, 250 kcmil and 2/0 AWG. Building feeders are either 500 kcmil or 250 kcmil. Please request the size from the University electrical engineering staff.
- 1.5. Cables shall be colored coded with tape: A-Phase (Black), B-Phase (Red), C-Phase (Blue).
- 1.6. Request the University standard medium voltage cable specification from the electrical engineering staff for complete details.

2. Terminations

- 2.1. Primary cable terminations shall be made of Class I, heat-shrink or cold-shrink termination kits as manufactured by Raychem or 3M.
- 2.2. Primary cable splices shall be 600-amp modular type (3M 5815 series or equivalent Raychem series) with a cold shrink sleeve.

3. Ground Wire

- 3.1. All medium voltage circuits shall contain a 250 kcmil, THHN, copper conductor ground wire with a green jacket.

4. Installation

- 4.1. University Electric Utilities shall furnish, install, splice and terminate all primary cables between the point of connection to the existing campus distribution feeders and the line side terminals of the first primary switch for each feeder to the building.
- 4.2. Installation and splicing of shielded medium voltage conductors inside of the building shall be by Electric Utilities.
- 4.3. Installation of non-shielded medium voltage conductors shall be by the contractor.
- 4.4. If approved by Electric utilities, any shielded 15kV conductors not installed by Electric Utilities shall be installed by qualified personnel with a minimum of 5 years' experience. References and past experience shall be provided to the University upon request.

END OF SECTION

26 05 19 LOW-VOLTAGE POWER CONDUCTORS AND CABLES

1. General

- 1.1. **PROHIBITED:** Aluminum conductors, without approval by University electrical engineering staff.
 - 1.1.A. In the event an aluminum conductor is accepted by the University electrical engineering staff, it must conform to the following requirements:
 - 1.1.A.1. Aluminum conductors shall be limited to circuits with switches or circuit breakers that can accept a standard one-hole lug or a pin lug (a.k.a. “Mac Adaptor”). Anything else is strictly prohibited. If the breaker/switch cannot accept these two types of lugs, then a different breaker/switch must be installed or copper conductors must be used.
 - 1.1.A.2. Absolutely no splices allowed.
 - 1.1.A.3. **PROHIBITED:** Installing aluminum conductors underground.
 - 1.1.A.4. All terminations shall be non-reversible crimps, and installed with a UL listed lug and die crimping system. The use of one manufacturer’s lug with another manufacturer’s die is not acceptable.
 - 1.1.A.5. Terminations must be installed by electricians trained by the lug and crimp manufacturer’s authorized representative.
 - 1.1.A.6. The crimping dies shall emboss the crimping die number on the lug to verify that the lug and crimp numbers match.
 - 1.1.A.7. All conductors shall be wire brushed before the lug is crimped.
 - 1.1.A.8. The number of crimps per lug shall match the manufacturer’s requirements.
- 1.2. All feeder splices must be approved by University of Minnesota Electrical Engineer.
- 1.3. Minimum size of conductors for lighting and power circuits is #12 AWG.
- 1.4. Conductors for site lighting installed in underground PVC conduit shall be a minimum of #8 AWG and have type XHHW insulation on conductors.
- 1.5. 600-volt conductor insulation shall be rated 90 degrees C minimum in dry conditions.
- 1.6. Conductors #10 AWG and smaller are preferred to be solid wire.
 - 1.6.A. Exception: Stranded conductors may be used in lieu of solid wire provided the wire is properly terminated with compression type connectors or between an approved clamp plate that is secured with a screw. Stranded conductors under a plain screw is not allowed.
 - 1.6.B. Exception: Conductors #10 AWG and smaller installed in flexible conduit at terminal connections of rotating, vibrating or moveable equipment shall be of

stranded wire. Wire shall be terminated in an approved crimp type connector.

- 1.7. Provide continuous color coded conductors insulations for #8 AWG and larger.
- 1.8. Conductors for DC circuits shall have type XHHW insulation on conductors.
- 1.9. Hydraulic crimping tool dies shall impress the die's conductor size range into the crimp.
- 1.10. Neutral conductor capacity shall be increased, where necessary, for harmonic current. Apply the necessary NEC required de-ratings for current carrying conductors.

2. MC Cable

- 2.1. MC cable is allowed for device wiring within rooms with accessible ceilings and to device boxes in stud wall construction.
- 2.2. Each room shall be fed with a ¾" minimum home run conduit terminated at a junction box in the accessible ceiling space.
- 2.3. Cable shall be routed parallel or perpendicular to building members in a neat and orderly fashion.
- 2.4. Shall not be used on circuits larger than #10 AWG.

END OF SECTION

26 05 26 GROUNDING AND BONDING FOR ELECTRICAL SYSTEMS

1. General

- 1.1. **PROHIBITED:** Aluminum conductors
- 1.2. Provide continuous color green insulation for all equipment ground conductors.
- 1.3. Raceway systems shall incorporate a separate grounding conductor, integrally connected to all devices, the raceway and the building. Conduit, wireway or cable tray shall not be used as the equipment ground conductor.
- 1.4. Use only non-metallic conduit for ground conductors run separately from phase conductors or common grounding electrode conductors. Supports encircling conduits shall be non-ferrous.
- 1.5. Install a minimum of two (2) 4/0 AWG copper bonding conductors for:
 - 1.5.A. All equipment located in electric vaults
 - 1.5.B. Service entrance equipment
 - 1.5.C. All MCC's or switchboards rated 1,000A or larger.
- 1.6. Isolated ground systems shall have a single connection to the building ground system located in the building service electrical room.
- 1.7. Exterior lighting bases shall have a ground rod installed within the base and exposed a minimum of 3 inches above the concrete.
- 1.8. Ground rod shall be copper coated with steel core. Use of galvanized steel rods or copper clad rods is prohibited.
 - 1.8.A. Copper coating shall have a minimum thickness of 10 mils.
- 1.9. Exterior Padmount equipment shall be provided with a ground ring.
 - 1.9.A. Provide a minimum of 4 – 10' ground rods.
 - 1.9.B. Ground conductors shall be #4/0 AWG bare cu, or larger.
 - 1.9.C. Underground grounding connections shall be either exothermic weld type or non-reversible compression connectors that are compliant with IEEE Standard 837.

2. Electric Vaults

- 2.1. Provide a minimum of one ground bus per electrical vault with dimensions of 6 feet long by 4 inches wide by ¼ inch thick. Mount the bus on stand-off insulators 18 inches above the floor.
- 2.2. Ground compression connections in the high voltage electrical vault shall be 2 hole, UL 467 listed (e.g. ground conductor to ground bus).
- 2.3. All medium voltage circuits shall have one, 600 volt, 250 kcmil, green colored, equipment grounding conductor in all raceways.

- 2.4. All conduit with medium voltage circuits shall have ground bond bushings, and all cable tray with medium voltage circuits shall be bonded to ground with a 4/0 AWG conductor.
- 2.5. Install a minimum of two (2) 4/0 AWG copper bonding conductors for all medium voltage transformers, 15 or 5 kV switches, service entrance rated switchboards
- 2.6. Underground grounding connections shall be either exothermic weld type or non-reversible compression connectors that are compliant with IEEE Standard 837.
- 2.7. Provide a ground grid under all electric vaults.
 - 2.7.A. Vault ground grids do not take the place of NEC required grounding / bonding. A/E must verify compliance with all NEC grounding requirements.
 - 2.7.B. The ground grid system shall be bonded to the building perimeter ground loop, building “Ufer” ground, building steel, and lightning protection (if applicable).
 - 2.7.C. A minimum of two, 4/0 AWG, ground whips shall be installed from the ground grid up to each wall mounted ground bus, and to each equipment ground bus. Ground whips shall penetrate the slab on grade directly beneath the ground bus.
 - 2.7.D. Bond ground grid to reinforcing steel or building steel a maximum of 50 foot intervals.
 - 2.7.E. The University commissioning agent shall inspect and test, if necessary, the completed ground grid system prior to back-filling.
 - 2.7.F. The ground grid shall be designed using one of the two following methods:
 - 2.7.F.1. Prescriptive Method:
 - 2.7.F.1.a. Provide a grid consisting of #4/0 AWG copper conductors, spaced at intervals of 5ft or less.
 - 2.7.F.1.b. Provide one 10’ copper ground rod at each ground wire intersection, both along the perimeter and inside the grid.
 - 2.7.F.1.c. Ground grid must be square or rectangular in shape
 - 2.7.F.1.d. Minimum grid size: 900 sq ft
 - 2.7.F.1.e. Conductor burial depth: 12” min.
 - 2.7.F.1.f. Reference detail Figure 10 – Typical Ground Grid
 - 2.7.F.2. Custom Calculations:
 - 2.7.F.2.a. The ground grid system shall be designed to IEEE 80 requirements or any other industry approved methodology that clearly provides empirical data to back up the design of the ground grid for medium voltage systems.

- 2.7.F.2.b. Contact U of MN Electrical Engineering staff to obtain applicable information.
- 2.7.F.2.c. The ground grid design shall limit step and touch potentials within the vault to a safe level.
- 2.7.F.2.d. Ground grid shall be constructed of a minimum of #4/0 AWG copper conductors.
- 2.7.F.2.e. Ground rods shall be $\frac{3}{4}$ inch diameter and 10 feet long. Ground wells made of schedule 40 steel casing and backfilled with bentonite may also be required to achieve the proper step and touch potentials.
- 2.7.F.2.f. The ground grid design calculation shall be submitted to the University electrical engineering staff for review.

END OF SECTION

26 05 29 HANGERS AND SUPPORTS FOR ELECTRICAL SYSTEMS

1. General

- 1.1. **Prohibited:** Use of aircraft wire type (Gripple, Kwikwire or similar) conduit supports in high voltage vaults, electrical rooms or mechanical rooms. Use of aircraft wire hangers is acceptable in other locations.
- 1.2. Conduit fasteners shall be compatible with the atmosphere of the area in which they are installed.
- 1.3. **Prohibited:** Lead, wood or fiber anchors that support raceway or equipment.

END OF SECTION

26 05 33 RACEWAY AND BOXES FOR ELECTRICAL SYSTEMS

2. General

- 2.1. Minimum conduit size shall be $\frac{3}{4}$ inch.
- 2.2. Below slab or underground conduit shall be schedule 40 PVC. PVC conduit is not allowed as an interior or exterior surface mounted raceway.
- 2.3. Conduit that penetrates a slab in exposed areas (e.g. in mechanical rooms electric rooms, and electric vaults, closets, etc.) shall be made of rigid galvanized steel up to a height of 24 inches where it can transition to the specified building conduit.
- 2.4. Conduit installed on the exterior of the building and above grade shall be rigid galvanized steel.
- 2.5. All conduit for 15kV and 5 kV circuits shall be rigid galvanized steel.
- 2.6. Conduit can be encased in concrete walls and shall be schedule 40 PVC.
 - 2.6.A. **Prohibited:** Conduit encased inside the slab on grade.
 - 2.6.B. Encased conduit shall be bundled in designated routes and redlined on the design drawings by the contractor.
- 2.7. **Prohibited:** PVC coated conduit.
- 2.8. The use of flexible conduit shall be limited to recess lighting luminaries, motors and vibrating equipment, with a maximum length not to exceed 6 feet.

3. Underground Raceways (Non-Duct Bank)

- 3.1. Schedule 40 PVC, a minimum of 1 inch. Use schedule 80 PVC where exposed to potential damage.
- 3.2. Fiberglass elbows shall be used in buried PVC conduit runs of 2 inch and larger.
- 3.3. To locate concealed circuits in the future, install wiring for street lighting services within 24 inches of inner curb lines. Install wiring for site lighting within 12 inches of walkways.
- 3.4. Conduit can be routed parallel to but not under walkways and/or driveways, unless it is a perpendicular crossing.
- 3.5. All pedestrian and street lighting circuits shall be installed in conduit.

4. Concrete Embedded Raceways (Above Grade)

- 4.1. Use of concrete encased raceways must be approved by University Electrical Engineering Staff
- 4.2. If approved, concrete encased raceways shall comply with the following requirements:
 - 4.2.A. All feeders shall be schedule 40 PVC. Use of ENT is prohibited for all feeders
 - 4.2.B. Minimum conduit size shall be 1"

5. Electric Vault Raceway

- 5.1. All 13.8 kV and 4.16 kV circuits shall be installed in rigid galvanized steel conduit or heavy duty, aluminum ladder type cable tray.
- 5.2. Conduit size for all 13.8 kV circuits shall be a minimum of 4 inch conduit for 2/0 AWG, and 5 inch for 250 and 500 kcmil.
- 5.3. Size pull boxes (for circuits greater than 600 volts) in accordance with the NEC, and make them large enough to accommodate cable drip loops.
- 5.4. All conduit and boxes with 15 kV rated circuits shall be painted safety orange with the nominal voltage stenciled on it every 10 feet. All conduit and boxes with 5 kV rated circuits shall be painted red with the nominal voltage painted on it every 10 feet.

6. Steam Tunnel Raceway

- 6.1. All conduit in steam tunnels shall be rigid galvanized steel with cast fittings and boxes.

7. Parking Facility Raceway

- 7.1. Conduit for parking ramps shall be surface mounted (not placed within any encased concrete).
- 7.2. Shall be rigid galvanized steel on all vertical surfaces, including transitions to horizontal.

8. Boxes

- 8.1. Where rigid galvanized steel conduit is installed, use cast boxes.
- 8.2. To reduce sound transmission, wall outlet boxes shall not be installed back-to-back in partitions.
- 8.3. Locate boxes that are installed in concrete block walls at the block joint.
- 8.4. Provide removable covers with grab handles for medium voltage pull boxes. Hinged covers are preferred where possible.
- 8.5. Paint the cover of all fire alarm boxes red.
- 8.6. Paint the cover of all network and communications boxes blue.
- 8.7. Reference Division 23 Standards for BAS / building automation junction box color.
- 8.8. Surface boxes used on the exterior of a building, or on the site, shall be rated for outdoor use and weather-tight.
- 8.9. Floor boxes in slab-on-grade shall be rated for wet conditions. All other floor boxes shall be designed and rated to prevent water infiltration for carpet and floor cleaning.

END OF SECTION

26 05 36 CABLE TRAYS FOR ELECTRICAL SYSTEMS

1. General

- 1.1. **PROHIBITED:** Use of cable tray in the building for power wiring with the exception of 5 kV and 15 kV rated circuits in high voltage electric vaults.
- 1.2. Cable tray installed in electric vaults must have a minimum of 1' clearance between the top of the cable tray and the lowest hanging obstruction.
- 1.3. Please refer to the appropriate standards divisions for use of cable tray with other systems (e.g. fire protection, technology, etc.).

END OF SECTION

26 05 43 UNDERGROUND DUCTS AND RACEWAYS FOR ELECTRICAL SYSTEMS

1. Design and Installation

- 1.1. All medium voltage electrical distribution and building service entrance circuits shall be routed in underground duct banks.
 - 1.1.A. Include related U of M standard details in the contract documents and edit the drawings as required for the project.
- 1.2. A scaled duct bank plan and profile shall be included in the civil engineering contract documents with typical details referenced to the electrical contract documents. Plan and profile drawing shall, but not be limited to, include station markers, percent slopes of duct bank sections, degrees of bends, inverts of duct bank entrance into a structure, invert of manhole floor, grade elevations, height and width of manholes.
- 1.3. A cable pulling calculation shall be performed and submitted to the U of M electrical engineering staff
 - 1.3.A. The duct bank design shall not exceed a cable sidewall pressure of 500 pounds/foot at any point in the duct.
 - 1.3.B. The design shall use a minimum coefficient of dynamic friction of 0.35
 - 1.3.B.1. Design engineer shall increase coefficient where field conditions warrant
 - 1.3.C. If the calculations indicate a restriction on the direction of pull, these restrictions shall be included in the contract documents.
- 1.4. All duct banks shall be sloped to drain away from building and into manholes. The slope shall be a minimum of 4 inches per 100 feet. Avoid trapped runs.
 - 1.4.A. If this requirement cannot be met and an exception is granted, the electric vault in the building shall be designed with a sump drain system.
- 1.5. Duct bank conduits shall not enter indoor equipment directly from the duct bank. Provide a pull box or other water break to prevent water from flowing from the duct bank into the equipment.
- 1.6. Shall have a minimum of 30 inches of cover.
 - 1.6.A. Exception: Only where required by obstructions or entrances to manholes or structures. All exceptions must be approved by U of M electrical engineering staff.
- 1.7. Duct banks or conduits shall not be located within 5 feet of a buried steam line in any direction. If it becomes necessary to cross a steam line, University electrical engineering staff must approve acceptable insulation of crossing.
- 1.8. Use schedule 40 PVC, 5-inch minimum conduit for medium voltage circuits.
 - 1.8.A. Duct banks constructed one barrel high shall use RGS conduits.

- 1.9. When required, provide one – 1” PVC communications conduit in each duct bank.
- 1.10. Conduit bends greater than 10 degrees must be made of either fiberglass with PVC couplings or rigid galvanized steel, and shall have a minimum radius of 60 inches.
- 1.11. Include steel reinforcing per the drawing details. Rebar shall overlap at the joints by a minimum of 18 inches, and shall have staggered joints.
- 1.12. Use PVC end bells at the ends of a duct bank into a structure. If rigid galvanized steel conduit is used, the ends shall have a grounding bushing.
- 1.13. The face of the duct bank shall be recessed with respect to the interior wall of the structure with a 2-inch chamfer.
- 1.14. Shall use standard conduit spacers with 2 inches between conduits and 3 inches on the bottom, top and sides. Conduit shall be supported a minimum of every 4 feet.
- 1.15. No conduit bellies or sags between supports or between manholes.
- 1.16. Conduits shall be cleaned, after installation, with a stiff wire brush sized for the conduit. Use of rags is not acceptable. A rubber squeegee, sized for the conduit, shall be used if there is mud in the conduit. Cleaning shall be witnessed by the Electric Utilities staff.
- 1.17. Conduit integrity shall be verified with a 5-inch mandrel. Pull through of mandrel shall be witnessed by University Electric Utilities.
- 1.18. Each conduit shall have a pull string with distance markers installed after verification with a mandrel.

2. Encasement

- 2.1. Duct bank shall be formed to minimize the width since underground space is a premium in many locations.
- 2.2. Concrete shall be rated a minimum of 3,000 pounds and shall be allowed to cure for a minimum of 48 hours or have a minimum of 80 percent strength before back filling.
 - 2.2.A. Compaction of backfill along the sides or top of duct bank is prohibited until concrete has cured for 48 hours or has a minimum 80 percent strength.
 - 2.2.B. If high strength or fast curing concrete is used, the contractor may backfill earlier than 48 hours after pouring only if test cylinders are provided and tested to have a minimum strength of 2,400 psi.
- 2.3. A continuous concrete pour between manholes is preferred. If this is cannot be achieved, a step detail shall be used for cold joints and must be approved by the U of M electrical engineering staff.
- 2.4. Each cold joint must be approved by the U of M electrical engineering staff.
- 2.5. Specify a minimum of 3 inches of concrete cover over the top of the conduits.

- 2.6. Concrete shall be vibrated. Air pockets in the concrete will result in rejection of the duct bank.
- 2.7. If the expected minimum temperature during the concrete curing period is below 32°F, concrete pours must be approved by University of Minnesota electrical engineering staff.
 - 2.7.A. Contractor shall submit a detailed plan for the cold weather concrete work for review by University of Minnesota electrical engineering staff.

END OF SECTION

26 05 43.19 MANHOLES AND HARDWARE

1. Manholes

- 1.1. Review layout, dimensions and routed of cable in all manholes with U of M electrical engineering staff during design to provide access, maintainability and space for extending feeders in the future.
- 1.2. The standard manhole inside dimensions are 12'W x 12'L x 7'H for main line duct bank routes. For dedicated runs to buildings, a 10'W x 10'L x 7'H inside dimension manhole may be used. Exceptions to these manhole sizes may be used, but must be approved by the U of M electrical engineering staff.
- 1.3. Manhole floor to top of manhole cover height shall be 11' max.
- 1.4. Can be pre-cast or cast-in-place.
- 1.5. Precast manholes cannot be clam type (i.e. two part manholes with the seam mid-way up the wall).
- 1.6. Precast manhole sections must be sealed with a double row of mastic.
- 1.7. Windows in manholes can be field cut. However, the field cut must not exceed 1 inch of over cutting.
- 1.8. Manholes must be set level to avoid water from pooling in the corners.
- 1.9. Refer to typical manhole drawing for details on construction.
- 1.10. Non University Electric Utility personnel are strictly prohibited from entering any manhole containing energized cables, unless approved to do so by Electric Utilities.

2. Hardware

- 2.1. Manhole castings shall be:
 - 2.1.A. Neenah Foundry: Cat #: R-1740-D2
 - 2.1.B. East Jordan:
 - 2.1.B.1. 1581 frame. Product # 00158111
 - 2.1.B.2. 1581 E and 1040 A cover. Product # 00158055 and 00104115
 - 2.1.C. Owner approved equal.
- 2.2. Steel galvanized ladders inside the manhole are not required.
- 2.3. Each manhole shall have 2 – 10' x 3/4" copper ground rods installed in opposite corners.
- 2.4. Each manhole shall have 2 – 24" x 4" ground buses installed on opposite walls. The ground bus shall have pre-drilled 1/2" holes with NEMA 2-hole spacing. Ground buses shall be installed 6 feet up from the floor of the manhole.
- 2.5. All ground components shall be bonded inside the manhole to the ground rods and both ground rods shall be bonded to each other. All ground connections in the

manhole, including the wire lugs, shall be UL listed for underground use and shall comply with IEEE 837 standards.

END OF SECTION

26 05 53 ELECTRICAL SYSTEM IDENTIFICATION

1. General

- 1.1. Identification plates are required for electrical distribution equipment from the service through branch circuit panelboards, motors and motor control centers. Labels shall identify the operating voltage, equipment designation, and the source supplying the equipment.
 - 1.1.A. Engraved phenolic or similar
 - 1.1.B. Nameplates on equipment shall be attached with stainless steel screws
 - 1.1.C. Nameplates for normal equipment shall be black with white lettering.
 - 1.1.D. Nameplates for emergency and standby power equipment shall be red with white lettering.
 - 1.1.E. Nameplates shall be 1/8-inch-thick plastic plates with a minimum of 3/8-inch lettering.
 - 1.1.E.1. Larger, 1-inch lettering may be required for main switchboards and distribution panels.
- 1.2. All high voltage vaults shall be identified by their function and in numerical order (e.g. “HIGH VOLTAGE SWITCHING VAULT 1”, or “HIGH VOLTAGE TRANSFORMER VAULT 2”)
- 1.3. The primary service equipment, transformers and switchboards must be identified with an alpha-numeric label based on the vault number or the transformer serving that piece of equipment (e.g. “TRANSFORMER 1A” feeds “SWITCHBOARD 1A” or “TRANSFORMER 2B” feeds “SWITCHBOARD 2B”).
- 1.4. 15 kV switchgear assemblies shall be identified by individual bay numbers on a per switch basis. Starting from left-to-right, the first switch would be identified as “BAY 101” if it is located in Vault 1. If it is located in Vault 2, it would be “BAY 201”. The next switch would be “BAY 102” or “BAY 202”. In addition to the bay number, each switch shall identify the connected load. For instance, a switch may be labeled “BAY 101” on the first line, and “TRANSFORMER 1A” on the second line.
- 1.5. Provide nameplates for all equipment
- 1.6. All 15 kV conduit and pullboxes shall be painted safety orange and stenciled with the voltage every 10 feet.
- 1.7. All 15 kV and 5 kV cable tray shall be stenciled with the voltage every 10 feet.
- 1.8. All 5 kV conduit shall be painted safety red and stenciled with the voltage every 10 feet.
- 1.9. All fire alarm box covers shall be painted red.
- 1.10. All communication box covers shall be painted blue.

1.11. Provide arc flash hazard labels for all equipment operating at greater than 50 volts.

1.11.A. Reference 26 05 73 for label requirements.

1.12. Equipment nameplates shall include the operating voltage and identify the upstream equipment / supplying equipment.

END OF SECTION

26 05 73 ELECTRICAL STUDIES

1. Short Circuit Studies

- 1.1. Short circuit studies shall comply with:
 - 1.1.A. IEEE 242
 - 1.1.B. IEEE 399
 - 1.1.C. IEEE 551
- 1.2. It is the A/E's responsibility for this study. It shall not be delegated to the Contractor within the contract documents. The A/E must perform the short circuit analysis and identify the necessary interrupting ratings on the equipment before the contractor purchases the equipment.
 - 1.2.A. It is acceptable for the A/E to contract with the selected equipment supplier, but the responsibility for the study must remain with the A/E, not the contractor.
- 1.3. Short circuit study shall be based on a maximum available fault current of 250 MVA (10 kA PER CIRCUIT) at 13.8 kV, 3 phase, with an X/R ratio of 20 and 85 MVA line-to-ground, with an X/R ratio of 15.
 - 1.3.A. Short circuit studies shall include the worst-case scenario of both 13.8 kV feeders tied in parallel at the secondary main switchgear.
 - 1.3.B. Transformer impedance: ANSI standard minus 7.5 percent tolerance.
 - 1.3.C. Motor contribution: Per IEEE 242 recommendations for equipment substations.
 - 1.3.D. Include the X/R ratio of fault current at all levels.

When system fault current X/R ratios exceed the standard equipment short circuit test X/R ratio, adjust the available fault current per IEEE guidelines.

2. Overcurrent Protective Device Coordination Studies

- 2.1. Overcurrent protective device coordination studies shall comply with:
 - 2.1.A. IEEE 399
- 2.2. It is the A/E's responsibility for this study. It shall not be delegated to the Contractor within the contract documents. The A/E must provide a preliminary coordination study that confirms the overcurrent protection coordination is feasible. Contract documents may require the contractor to submit the necessary overcurrent protective device characteristic curves to complete the A/E's final coordination study based on the specific equipment furnished.

- 2.2.A. It is acceptable for the A/E to contract with the selected equipment supplier, but the responsibility for the study must remain with the A/E, not the contractor.
- 2.3. All overcurrent protective devices shall coordinate to 0.10 seconds, unless otherwise required by code.
 - 2.3.A. If a circuit breaker maintenance switch is provided, loss of coordination while in maintenance mode is acceptable.
- 2.4. Selectively coordinate the emergency system per the NEC.
- 2.5. As-Builts: Update the coordination study based upon actual installed devices and include TCC graphs and settings in O&M manuals.

3. Arc Flash Hazard Studies

- 3.1. It is the A/E's responsibility for this study. It shall not be delegated to the Contractor within the contract documents. The A/E must perform the arc flash hazard analysis and identify areas with high arc flash hazard.
 - 3.1.A. The study does NOT include equipment operating at 13.8kV, including 13.8kV switchgear and service transformers.
- 3.2. Arc flash hazard studies shall comply with:
 - 3.2.A. IEEE 1584 - 2018
 - 3.2.B. IEEE 1584.1
 - 3.2.C. NFPA 70E – Latest Edition
- 3.3. Arc flash hazard studies shall evaluate the system with maximum and minimum available fault current to determine the worst-case scenario.

The objective is to not only verify the design but also identify the equipment that requires arc flash mitigation other than PPE to ensure the safety of a worker (e.g. areas greater than 40 cal/cm²).

- 3.3.A. Maximum current: As specified for short circuit studies
- 3.3.B. Minimum current:
 - 3.3.B.1. East Bank Campus: 3,000A
 - 3.3.B.2. West Bank Campus: 2,200A
 - 3.3.B.3. St Paul Campus: 2,200A

- 3.3.C. A/E shall identify areas in which equipment conductor spacing and working distance may differ from IEEE 1584 standard values. The A/E shall adjust the study parameters as required.
- 3.3.D. A/E shall verify equipment bus configuration. Where equipment bus configuration can not be determined, a horizontal configuration shall be assumed.
- 3.3.E. Arc Flash Hazard Labels – Provide arc flash hazard labels for all equipment operating at 50V or greater. Labels shall have the following information:
 - 3.3.E.1. Equipment Name – As shown on as-built drawings
 - 3.3.E.2. Where applicable – indicate if the label is associate with an arc flash line side or load side of the equipment main breaker.
 - 3.3.E.3. Date study was performed
 - 3.3.E.4. Calculated incident energy – Calories per square centime (cal/cm²)
 - 3.3.E.5. Arc flash boundary
 - 3.3.E.6. Working clearance and conductor gap, if not using IEEE 1584 standard values.
 - 3.3.E.7. Note when arc flash hazard is based on activation of upstream maintenance switch.
 - 3.3.E.8. See figures: ‘Sample Arc Flash Hazard Label Guidelines’ for additional information
- 3.3.F. Identification of high arc flash hazard – The following shall be considered high arc flash hazard areas:
 - 3.3.F.1. Incident energy exceeds 40 cal/cm²
- 3.3.G. Arc flash hazard mitigation – Areas of high arc flash hazard, as identified by the arc flash hazard study, shall be provided with means to reduce or mitigate the arc flash hazard.
 - 3.3.G.1. Use of zone selective interlocking is not preferred.
 - 3.3.G.2. Consideration shall be given to arc-resistant equipment where applicable.
 - 3.3.G.3. All arc flash hazard reduction methods must be discussed with, and approved by, Energy Management.
 - 3.3.G.4. If a remote breaker operator or racking device is specified, consideration shall be given to the operator power source. If required, provide a receptacle supplied by a control power transformer in the switchboard or a receptacle in the room, backed up by the building generator.

Arc-resistant equipment, remote breaker operators/control switches, maintenance switches, breaker remote racking devices, and integral arc detection systems are some of the acceptable options.

4. Electrical System Models

- 4.1. All system models, where used for any required system study, shall be submitted for review by University of Minnesota electrical engineering staff, prior to final construction documents being issued.
- 4.2. An as-built system model shall be submitted to the University of Minnesota for record purposes.
- 4.3. Provide a final report, in PDF form AND the system modelling software project files, including protective device libraries.

END OF SECTION

26 08 00 ELECTRICAL COMMISSIONING

1. General

- 1.1. Commissioning of electrical systems shall be self-performed by the University or a University hired commissioning agent, unless noted otherwise in these standards for specific equipment.
 - 1.1.A. Commissioning shall not be confused with the contractor's standard pre-functional tests of items such as connections and wiring before it is turned over for commissioning.
 - 1.1.B. Commissioning of systems is a component testing and functional startup process that ensures the systems to operate as designed and specified.
- 1.2. The contractor's role in commissioning shall be identified in the contract documents as a support role (i.e. removing panel covers, unbolting terminations, facilitating repairs of deficiencies identified during the commissioning process, etc.).
- 1.3. The contractor shall demonstrate or provide manufacturer's representatives to demonstrate the equipment and systems to University personnel, including operation and maintenance.
- 1.4. Specify that the contractor shall test to ensure that there are no ground bonds in panelboards and shall megger all buses and conductors for stray grounds.
- 1.5. Include a reference in Division 26 to the University commissioning standards for scope and requirements of the University commissioning so it is clear to the contractor what has to be completed before items are permanently covered up or energized.
- 1.6. Costs associated with the University self-performed commissioning will be a part of the project costs, but will not be included in the Division 26 contractor's scope.

2. A/E's Commissioning Responsibilities

- 2.1. Review of contract documents that clearly identify the design intent and define all operating sequences and functional requirements of the electrical service equipment, including protective schemes and automatic transfer schemes.
- 2.2. The commissioning specification in the contract documents, per these standards.
- 2.3. Resolution of design based deficiencies identified during the commissioning process.
- 2.4. Resolution of deficiencies identified during the commissioning process.
- 2.5. Retaining the services of an electrical testing contractor to perform verification tests.

3. Building Electrical Equipment and Systems to be Commissioned

- 3.1. The following equipment and/or installations will be component and functionally tested by the University commissioning agent:
 - 3.1.A. 15 kV and 5 kV switchgear.
 - 3.1.B. 15 kV and 5 kV cable.

- 3.1.C. Main building service transformers.
- 3.1.D. All transformers larger than 112.5kVA
- 3.1.E. 600V Busway (if applicable).
- 3.1.F. All circuit breakers with frame sizes 400 amps and larger, and all circuit breakers with adjustable trip settings.
 - 3.1.F.1. Requires A/E's overcurrent coordination study and settings.
- 3.1.G. Metering and associated instrument transformers.
- 3.1.H. Main switchboard GFI coordination, if applicable.
- 3.1.I. Any switches 200 amps and larger.
- 3.1.J. Ground grid beneath the high voltage vault and the building grounding. The contractor shall test the system ground fault performance when first installed and submit a report of the results. The University commissioning agent shall witness the test.
- 3.1.K. Generator(s).
 - 3.1.K.1. Full load test to be provided by the Division 26 contractor.
 - 3.1.K.1.a. Load bank test may not take place until the generator room is substantially complete.
 - 3.1.K.1.b. All louvers / dampers and their associated controllers must be installed and functional.
 - 3.1.K.1.c. Room and/or generator enclosure doors must be installed and closed during testing.
 - 3.1.K.2. Division 26 contractor shall assist with generator output circuit breaker testing
 - 3.1.K.3. Division 26 contractor shall assist with testing of generator alarms and shutdowns.
 - 3.1.K.4. Division 26 and 23 contractors shall assist with testing of generator room ventilation systems.
 - 3.1.K.5. Division 26 contractor shall assist with generator stator and rotor winding insulation testing.
 - 3.1.K.6. Division 26 contractor shall assist with generator stator and rotor winding resistance testing.
 - 3.1.K.7. Refer to Engine Generator section 263213 for more detail and contractor requirements.
- 3.1.L. Battery and/or UPS testing

- 3.1.L.1. Full load test to be provided by the Division 26 contractor.
Division
 - 3.1.L.1.a. Load bank test may not take place until the UPS room is substantially complete.
 - 3.1.L.1.b. All louvers / dampers and their associated controllers must be installed and functional.
 - 3.1.L.1.c. Room and/or UPS enclosure doors must be installed and closed during testing.
- 3.1.L.2. Division 26 contractor shall assist with UPS output circuit breaker testing
- 3.1.L.3. Division 26 contractor shall assist with testing of UPS alarms and shutdowns.
- 3.1.L.4. Division 26 and 23 contractors shall assist with testing of UPS room ventilation systems.
- 3.1.L.5. Refer to UPS section 263353 for more detail and contractor requirements.
- 3.1.M. Refer to Engine Generator section 263213 for more detail and contractor requirements.
- 3.1.N. Lighting control. Part or all of this system may fall within the Division 23 Building controls sub-contractor. Coordinate the contract documents accordingly. Specify specialty lighting control system testing by the control system manufacturer.

4. Manhole and Duct Bank Commissioning

- 4.1. Duct bank construction shall be visually inspected by the University commissioning agent prior to concrete encasement and backfill.
 - 4.1.A. The contractor shall remove and replace construction that is concealed without such inspection at no cost to the University.
 - 4.1.B. Inspections shall be scheduled with a minimum notice of 48 hours.
 - 4.1.C. Inspections shall only take place Monday – Friday, 7:30am – 3pm, excluding University Holidays.
- 4.2. Manholes that are constructed on site or pre-cast manhole installation shall be witnessed and inspected by the University commissioning agent.
- 4.3. Brushing and proving of duct bank barrels shall be performed by the Division 26 contractor and witnessed by the University commissioning agent.

5. Permanent Building Power and Substantial Completion of Main Service Equipment

- 5.1. All medium voltage systems and building service equipment shall be commissioned prior to first energization of building electrical service facilities.

- 5.1.A. All deficiencies identified during the commissioning process on the high voltage equipment and main service equipment shall be resolved and corrected prior to energization.
- 5.2. Refer to Section 260500, Part 4 for general service energization requirements.
- 5.3. The following requirements represent a minimum definition of substantial completion of the electrical service installation and shall be part of the project specifications. Additional requirements may apply to specific projects:
 - 5.3.A. A complete and up-to-date one-line diagram of the main service equipment showing actual ratings and nameplate information of the installed equipment.
 - 5.3.B. All electrical inspections of the main service equipment must be complete and signed off by the University electrical inspector.
 - 5.3.C. The building envelope, high voltage vault, and main service electrical room walls, floors, and ceilings shall be completed (per the room finish schedules) and provide protection of the equipment from wind, water, dust and physical damage.
 - 5.3.C.1. All touch up painting shall be completed in the high voltage vaults.
 - 5.3.D. All ground wires terminated and ground buses installed per Section 260526.
 - 5.3.E. High voltage vault and main electric service room floors and housekeeping pads shall be sealed.
 - 5.3.F. Doors, locks and stand-alone card reader shall be installed and operational (refer to High Voltage Vault requirements in Section 260500 for details).
 - 5.3.G. Medium voltage conduit is painted safety orange and stenciled with the appropriate voltage. Cable tray with 13.8 kV feeders is stenciled with the voltage.
 - 5.3.H. Permanent lighting and receptacles shall be installed and operational.
 - 5.3.I. Minimal filtered vault ventilation shall be operational immediately after the equipment is energized. It is understood that full design ventilation will not be available until those systems are commissioned at a later date.
 - 5.3.J. Work by all trades in the high voltage vault shall be completed (e.g. HVAC, and fire alarm systems).
 - 5.3.K. The HVAC “Off-Auto” switch installed in the vault and wired to the DDC system.
 - 5.3.L. All electrical equipment shall be thoroughly cleaned inside and out, including wipe down of all bus, bus supports, compartments and devices.
 - 5.3.M. The high voltage vault and main service electrical room shall be thoroughly cleaned, and all contractor materials and tools removed.
 - 5.3.N. Training and demonstration of electrical equipment in the high voltage vault and main service electrical room shall be completed.

- 5.3.O. O&M manuals for the equipment shall be submitted for review, approved and resubmitted in final form with the required number of copies. A minimum of one O&M manual set shall be placed in the **high** voltage vault spare fuse cabinet.
- 5.3.P. Spare fuses, renewal parts and tools required for all of the equipment shall be supplied and be placed in the **high** voltage vault.
- 5.3.Q. University installed mimic buses on the front of the electrical equipment shall be completed (Mimic bus furnished and installed by the University).
- 5.3.R. All University approved equipment nameplates (including the COMPASS nameplates) are installed.
- 5.4. The equipment shall be substantially complete prior to the electrical contractor's request for first energization from the campus distribution system. University Electric Utilities shall be notified in writing after substantial completion.
- 5.5. The electrical contractor shall provide a qualified electrician to serve as a full-time escort for unqualified personnel that are given access to the electrical vault during the construction period between initial energization and completion.
- 5.6. The **high** voltage vault shall not be used to store materials, used as an office space, break room, or for any other activity than its design intent.

6. Substantial Completion Building Emergency System Verification

- 6.1. Emergency system functionality shall be verified during a simulated primary service interruption, prior to substantial completion.
- 6.2. This test is required in addition to any verifications / testing required by the Building Codes Division.
- 6.3. University Electric Utilities will simulate primary electrical outage to the building. During the simulated outage, the University's commissioning agent(s) shall verify the emergency electrical system operates as designed.
- 6.4. Functional checks shall include:
 - 6.4.A. Emergency power available less than 10 seconds after outage begins
 - 6.4.B. All critical louvers / dampers function correctly.
 - 6.4.C. All transfer switch are operational.

END OF SECTION

26 09 00 INSTRUMENTATION AND CONTROL FOR ELECTRICAL SYSTEMS

1. Electrical Power Monitoring (SCADA)

- 1.1. The University Energy Management department operates a Supervisory Control And Data Acquisition System (SCADA) for the 13.8 kV distribution system and for the building main service electrical equipment. The SCADA system is a “front end” near real time database with a graphical user interface (GUI). It scans Intelligent Electronic Devices (IED) on the primary distribution system and in the building main service equipment for analog metering values, device status, and remote alarms.
- 1.2. Within a building, the SCADA system monitors the following:
 - 1.2.A. 15 kV switch position (open-closed).
 - 1.2.B. Main service transformer winding high temperature alarm or low oil level alarm, as applicable.
 - 1.2.C. Main service circuit breaker status (open-close & racked in-racked out).
 - 1.2.D. Tie breaker status (open-closed & racked in-racked out).
 - 1.2.E. Revenue meter analog values.
 - 1.2.F. Emergency generator “run”, “trouble” and “shutdown” status.
 - 1.2.G. Circuit breaker maintenance switch status (if provided).
- 1.3. See Figures: ‘Typical SCADA and BAS Monitored Points’ for additional information.
- 1.4. The meter that is installed within the main service equipment not only functions as the revenue meter, but also as a mini remote terminal unit (RTU) for monitoring the status points listed above. If there are more status points than is available on the meter, then a supplemental I/O device is furnished and installed by the University to monitor these points.
- 1.5. The SCADA system communication infrastructure is an Ethernet based network. The network used for SCADA is the network used for the building automation system. The University identifies this network as Energy01 MID. This network is not to be confused with the general University network, where office computers and printers are connected.
 - 1.5.A. A/E shall identify SCADA equipment as being assigned to the Energy01 MID network.
- 1.6. SCADA equipment, outside of the revenue meters, is furnished and installed by the University.
 - 1.6.A. The box or rack will be mounted in the high voltage vault.
 - 1.6.B. Space shall be reserved in the vault for this equipment.
 - 1.6.C. Interconnecting wiring will be furnished and installed by University Electrical Utilities.

- 1.6.D. Conduit and raceway for SCADA wiring between equipment and to the SCADA box/rack shall be furnished and installed by the Division 26 contractor.
- 1.6.E. A 120 volt, 20 amp, dedicated circuit shall be installed by the Division 26 contractor to the SCADA box/rack location. The 120 volt circuit shall originate from an emergency panel.
- 1.6.F. Two Ethernet jacks shall be installed by the Division 27 contractor to the SCADA box/rack location.
 - 1.6.F.1. One jack shall be on the general University network
 - 1.6.F.2. The other jack shall be on the Energy01 MID
- 1.6.G. Provide one Ethernet jack for each electric meter, relay or IED. Jack shall be on Energy01 MID network
- 1.6.H. Set up of the SCADA communications and programming of the SCADA devices (including the revenue meters) will be by the University electrical engineering staff.

END OF SECTION

26 09 23 LIGHTING CONTROL DEVICES

1. General

- 1.1. **PROHIBITED:** Dimming systems on metal halide lamps due to high maintenance costs and reduced lamp life.
- 1.2. Exterior lighting controls: Refer to section 26-56-00
- 1.3. Specify startup, demonstration and training for dimming systems to university personnel.
- 1.4. Provide three-way and four-way controls in long corridors, gymnasiums, auditoriums and other large areas.
- 1.5. Interior building corridor, office, storage, individual restroom, and similar spaces shall be controlled via occupancy sensors (wallbox, wall mount, or ceiling mount). Use “vandal-resistant” models for wallbox mounting in individual bathrooms and small public rooms. Use dual-switch models for offices and similar spaces requiring dual level lighting (switch closest to the door frame controls the low-light level). Dual-technology is typically preferred, but consider whether the use of one technology over another is more appropriate. When ceiling sensors are used, other than in corridors, provide switch(es) on the load side to allow some user control. Building with individual HVAC control of offices shall use sensors with output relays to allow the HVAC unit to shut down to minimum levels when no occupancy is sensed. Discuss control strategy with Energy Management at schematic design phase.
 - 1.5.A. **PROHIBITED:** Occupancy sensors or timer switches in electrical rooms/closets and in steam tunnels.
 - 1.5.B. **PROHIBITED:** Occupancy sensors in mechanical rooms. Timer switches are permitted in mechanical rooms when approved by Energy Management.
 - 1.5.C. Timer switches, where approved, must provide visual indication, such as by blinking the space lights, prior to turning off the space lights.
 - 1.5.D. **PROHIBITED:** Emergency lighting bypass relays without approval by University Electrical Engineering staff.
- 1.6. Basic on/off lighting scheduling and control shall be accomplished using non-proprietary modular components (such as occupancy sensors) or incorporated into the building DDC system. The responsibility of this programming shall fall under the Division 23 control system contractor. A sequence of operations for the lighting shall be included in the specifications for the Owner’s review.
- 1.7. Basic dimming controls shall be accomplished using non-proprietary modular components (such as local dimming switches) or incorporated in to the building DDC system. Provide the University with a detailed written description of the sequence of operation and control modes of all dimming systems.

- 1.8. Specialized lighting control shall be specified under Division 26. The lighting control shall be able to be integrated into the building DDC system using BACNet protocol, and shall be configurable with simple software and local interface. Customized programming that requires a service technician to compile and install is not acceptable.
 - 1.8.A. The use of lighting controllers for general building lighting is not acceptable.
 - 1.8.B. All lighting controllers must be approved by Energy Management
- 1.9. Provide a minimum of two programming devices, where required to program lighting control components. Provide a minimum of two copies of any proprietary programming software.
- 1.10. Occupancy sensors, when used for HVAC control, shall be shown on both electrical and mechanical drawings. The responsibilities of the division 23 and division 26 contractor shall be clearly defined.
- 1.11. **PROHIBITED:** Battery powered lighting control devices
- 1.12. **PROHIBITED:** Wireless lighting control devices

END OF SECTION

26 11 16 UNIT SUBSTATIONS

1. General

- 1.1. Unit Substation equipment operating at 1,000V or above, shall be located in the high voltage vault for operation and maintenance by the University Electric Utilities department.
 - 1.1.A. Distribution equipment operating below 1,000V shall not be installed in the high voltage vault unless approved by University Energy Management Engineering Staff.
- 1.2. All buildings shall receive two 13.8 kV, primary selective, radial feeders to be connected to 15 kV class switchgear. For a building where continuous electrical service is essential, utilize a minimum of two unit substations.
 - 1.2.A. Secondary switchboards shall be arranged in a main-tie-main configuration.
 - 1.2.B. 15kV switchgear shall be arranged in a main-tie-tie main configuration
 - 1.2.C. The option of implementing a primary, 13.8 kV automatic switching scheme needs to be discussed with the University electrical engineering staff before the start of the design.
- 1.3. Dual 13.8 kV feeders to a building shall have the following switchgear arrangements (See also Figures 1A & 1B for typical arrangements).
 - 1.3.A. Single transformer feeding the entire building: Duplex switch with common bus primary selective, two incoming, non-fused switches with a transformer switch and fuse bay off of common bus.
 - 1.3.B. Multiple transformers feeding the building: Split bus 13.8 kV primary with two tie switches, connected in series. Two incoming, non-fused switches and two non-fused tie switches, connected in series. Fused transformer feeder switches split between the two buses.
- 1.4. The basic configuration of a unit substation shall be composed of 15 kV class fused disconnect switch, dry-type power transformer, and a main secondary disconnect device. However, the physical assembly of this configuration can take on a variety of arrangements.

Refer to the Sections 261216, 261316 and 262413 of this standard for further details on this equipment. Refer to Figures for typical one line diagrams of a unit substation.

- 1.5. For a building where there are chillers installed, each chiller shall have its own dedicated unit substation, or shall be powered from a main-tie-main unit substation that is dedicated to serving multiple chillers. The chiller unit substation shall not have non-chiller related building loads connected to it (e.g. lighting, receptacles, fans, etc.).

- 1.5.A. The secondary voltage of a chiller unit substation can be either 480 volt or 4,160 volt.
- 1.6. The primary disconnect switch for each unit substation does not have to be close coupled to the transformer, but must be in visible sight from the transformer location. If the transformer is located in another high voltage vault from the main incoming 15 kV switchgear, a non-fused primary disconnect switch must be added to the transformer for maintenance purposes.
- 1.7. The main secondary disconnect device must be a draw-out device for a visible disconnect, and can be located either in the high voltage vault or in the nearby low voltage electrical room. If it is located in the high voltage vault, it will be inaccessible to the building facilities management personnel. Therefore, a similar disconnect device must also be located at the main service switchboard. The main disconnect device can only be located in the low voltage electrical room if the tap off of the transformer meets all code requirements.
- 1.7.A. **EXCEPTION:** If an exception was granted to allow a single-ended electrical service to a building, main secondary disconnects rated less than 1,200A are not required to be draw-out type.
- 1.8. **PROHIBITED:** The secondary electrical connection between the unit substation transformer and the main secondary circuit breaker (located outside of the vault) shall not be comprised of bus duct or busway. Only cable and conduit or cable bus is allowed.
- 1.9. If installed underground, provide one spare conduit between 15kV switchgear and service transformers.
- 1.10. If installed underground, provide one spare conduit between service transformers and service disconnects.

END OF SECTION

26 12 16 DRY-TYPE MEDIUM VOLTAGE TRANSFORMERS

1. General

- 1.1. Medium voltage transformers shall be dry-type. Oil-filled transformers are not allowed without approval from the U of M electrical engineering staff.

Cast coil transformers may be required for applications in adverse environmental conditions, however, this is rarely required and should be discussed with the University electrical engineering staff before specifying.

- 1.2. Transformers shall be sized for natural cooling. Forced air fans are not allowed without approval from the U of M electrical engineering staff.
- 1.3. Transformers shall be sized to support all building loads and allow for an additional 20 percent future growth.
- 1.4. Due to upstream protective relay coordination limitations, transformers shall not exceed 1500 kVA air-to-air rating with a maximum 125E primary protective fuse.
- 1.5. Transformers that are not within eyesight of their primary disconnect device shall be equipped with a 15 kV rated disconnect switch.
- 1.6. The transformer shall have AB Chance type grounding ball studs mounted on the primary terminals or on the close-coupled, primary disconnect switch, and on the ground bus. Ball studs must be accessible, after removing a cover or opening a door, with a hot-stick tool for attaching a grounding cluster. The minimum working clearance for this is 72 inches.
- 1.7. Provide a minimum of 72 inches of clearance in front of the transformer. Provide a minimum of 30 inches from walls or from other equipment to the rear. If any rear access for maintenance is required, then the rear clearance shall be 72 inches minimum.

2. Design

- 2.1. Transformer windings can be aluminum or copper.
- 2.2. The core and coil shall:
 - 2.2.A. Comply with ANSI C57.12.01 and other applicable codes.
 - 2.2.B. Be tested per ANSI C57.12.91
 - 2.2.C. Have a 220 degree C Vacuum Pressure Impregnated (VPI) insulation system.
 - 2.2.D. Have a 115 degree C, maximum, temperature rise and comply with the Minnesota Energy Code.
 - 2.2.E. Have a standard 5.75 percent impedance down to a minimum 5 percent, unless specific design considerations dictate otherwise.

- 2.2.F. Have a 95 kV primary BIL and 30 kV secondary BIL rating without the use of surge arrestors.
- 2.2.G. Have a 13.8 kV Delta primary winding and a 480-277V or 208-120V Grounded-Wye secondary winding.
- 2.2.H. Transformer primary windings shall be disk type.
- 2.2.I. PROHIBITED: Layer or barrel windings.
- 2.2.J. Include two, 2-1/2 percent taps FCAN and two, 2-1/2 percent taps FCBN. Tap connections shall be on the front side of the transformer.
- 2.2.K. Have a maximum 62 dB noise level.
- 2.2.L. Have 10 kV rated, 8.4kV MCOV surge arrestors mounted at the primary terminals. Arrestors shall be bonded to ground with a copper conductor and shall not use the frame of the enclosure as the ground path.
- 2.3. When installed in an unconditioned space, or provided with cooling fans, each transformer shall have a digital fan controller with a temperature sensor in each winding. The controller shall have manual and automatic control with a temperature readout for each winding and for the peak winding temperature. The controller shall be programmable to automatically test cooling fans (when approved) and shall have dry type alarm contacts for remote monitoring. Fan controller shall be powered by an external 120-volt source. Internal control power transformers are not allowed.
- 2.4. Primary bus bars shall not be supported by red glastic board.
- 2.5. The minimum distance from the point where the 15 kV cable enters the transformer compartment to the primary terminals shall be 36 inches.
- 2.6. Include a knock-down enclosure that allows the core and coil to be removed without disturbing adjacent equipment sections.
- 2.7. Provide a continuous, internal ground bus through all sections of a secondary unit substation, including primary and secondary switch bays, and the transformer where applicable.
- 2.8. Provide vibration isolation between core and mounting structure and flexible bus connections to primary and secondary terminals to minimize noise transmission.
- 2.9. Provide IR windows for primary and secondary cable terminations
 - 2.9.A. Windows shall be centered over cable terminations and allow for thermographic analysis of all terminations.
 - 2.9.B. IR windows shall be IRISS CAP-CT-24. All exceptions must be approved by University Electrical Engineering staff.

END OF SECTION

26 12 19 PAD-MOUNTED, LIQUID FILLED MEDIUM VOLTAGE TRANSFORMERS

1. General

- 1.1. Medium voltage transformers shall be dry-type. Oil-filled transformers are not allowed without approval from the U of M electrical engineering staff.**
- 1.2. If an exception is granted, liquid filled transformer shall comply with the requirements below.
- 1.3. Transformers shall be sized for natural cooling. Forced air fans are not allowed without approval from the U of M electrical engineering staff.
- 1.4. Transformers shall be sized to support all building loads and allow for an additional 20 percent future growth.
- 1.5. Due to upstream protective relay coordination limitations, transformers shall not exceed 1500 kVA air rating with a maximum 125E primary protective fuse.
 - 1.5.A. All fuses shall be expulsion type, located outside of the transformer tank.
 - 1.5.B. Use of integral oil immersed fuses is prohibited.
- 1.6. Transformers shall be equipped with a 15 kV rated disconnect switch.
 - 1.6.A. All oil switches shall be on-off type. Use of T-Blade or V-Blade switches is prohibited.
- 1.7. Provide a minimum of 72 inches of clearance in front of the transformer. Provide a minimum of 36 inches around all other sides.
- 1.8. For all transformers 500kVA and larger, specify wire supports in the secondary compartment to relieve strain on the low voltage bushings
- 1.9. Provide separation between oil filled transformers and campus buildings per the latest version of Factory Mutual - FM Global Data Sheet 5-4

2. Design

- 2.1. Transformer windings can be aluminum or copper.
- 2.2. The core and coil shall:
 - 2.2.A. Have a 65 degree C, maximum, temperature rise and comply with the Minnesota Energy Code.
 - 2.2.B. Have a standard 5.75 percent impedance down to a minimum 5 percent, unless specific design considerations dictate otherwise.
 - 2.2.C. Have a 95 kV primary BIL and 30 kV secondary BIL rating without the use of surge arrestors.
 - 2.2.D. Have a 13.8 kV Delta primary winding and a 480-277V or 208-120V Grounded-Wye secondary winding.

- 2.2.E. Include two, 2-1/2 percent taps FCAN and two, 2-1/2 percent taps FCBN. Tap changer shall be externally operable and pad-lockable.
- 2.3. Provide 10 kV rated, 8.4kV MCOV surge arrestors
 - 2.3.A. Arresters shall be located in an upstream indoor disconnect switch or shall be elbow type.
 - 2.3.B. If using elbow type arresters, specify six bushings in a loop feed arrangement. Use of feed thru inserts is prohibited.
- 2.4. Each transformer shall have an oil level monitor. The level monitor shall be provided with a local display and be provided with one set of N.O. / N.C. low oil level alarm contacts.
 - 2.4.A. The alarm contacts shall be wired to a terminal block located in the high voltage compartment of dead front transformers or the low voltage compartment of live front transformers.
- 2.5. Provide a 1-inch drain valve with sampler. The valve shall be located in the high voltage compartment of dead front transformers or the low voltage compartment of live-front transformers.
- 2.6. Provide a dial type oil temperature gauge.

3. Installation

- 3.1. Pad-mounted transformers shall be installed on a concrete equipment pad
 - 3.1.A. Equipment pad shall extend a minimum of 1" above finished graded
 - 3.1.B. Equipment pad shall extend no more than 6" above finished grade, at the highest point.
 - 3.1.C. Pad shall extend no more than 6" beyond the edge of the equipment
 - 3.1.D. Pad shall include rebar reinforcement.
 - 3.1.E. Pad design must be approved by University Electrical Engineering staff prior to construction.
 - 3.1.F. Provide sleeves for all conduit penetrations in equipment pad. Do not pour conduits directly in to the equipment pad.

END OF SECTION

26 13 16 MEDIUM VOLTAGE FUSIBLE INTERRUPTER SWITCHGEAR

1. General

- 1.1. Provide a dual primary selective feed to each 13.8 kV service point in the building.
- 1.2. Switching equipment shall be indoors and shall be metal-enclosed, air-insulated, manually operated and contain load interrupter switchgear.
 - 1.2.A. Solid dielectric, vault style switchgear is an alternate option for special circumstances. This option must be discussed with the University electrical engineering staff.
- 1.3. Specifications shall require complete physical layout, schematic, and wiring diagrams be submitted for review by the University electrical engineering staff. All control wiring shall be permanently labeled at both ends with opposite end wire markers that correspond to the wiring diagrams.
- 1.4. Specifications shall require that service switchboard final as-built drawings be provided in AutoCAD format.

2. Switchgear Operation

- 2.1. Normal operation of the switchgear is to have the two main incoming switches normally closed and the tie switch normally open.
- 2.2. Primary switchgear with dual primary selective feeders shall be able to perform closed-transition-transfer between sources without interrupting service to the building. To prevent accidental paralleling of the two incoming sources, Kirk key mechanical interlocks shall be provided for the main-tie-main switches. However, additional keys shall be provided as necessary to perform the closed transition switching.

3. Switchgear General Construction

- 3.1. Shall be compliant with the relevant ANSI, IEEE, and UL standards.
- 3.2. Rear access switchgear is required with a minimum of 5 feet of clearance behind the switchgear. Front access only switchgear is not preferred.
 - 3.2.A. Sufficient cable space for training, termination and mechanical support must be provided for 500 kcmil, 15 kV single conductor cables.
 - 3.2.B. Specify hinged covers for rear compartment of switchgear.
- 3.3. Copper bus with full voltage epoxy coated insulation or insulated sleeves, and removable boots for all bolted connections including the cable termination points.
- 3.4. Fully grounded metal barriers between bays, including the main bus compartment, with insulating bushings for bus penetrations.
- 3.5. Continuous 2" x ¼" copper ground bus through all bays. A larger ground bus may be specified if needed to accommodate proper ground protection.

- 3.6. All 15kV class switches shall be provided with AB Chance grounding ball studs in a hot-stick accessible location.
 - 3.6.A. Provide one stud for each phase and ground.
 - 3.6.B. Studs shall be located on the line side of each switch. Studs are not required on the bus side of each switch.
- 3.7. Switches shall be provided with AB Chance grounding ball studs External operating handle with padlock that clearly indicates switch position. The switch handle shall be lockable in both the open and closed positions.
- 3.8. Phase arrangement A-B-C, left to right, front to back and top to bottom as viewed from the front.
- 3.9. All switches must open in a downward direction to be failsafe open if the mechanical linkage fails.
- 3.10. Safety glass viewing window that allow all switchblades to be seen in the open and closed positions.
- 3.11. All switches with cable terminations shall include IR windows.
 - 3.11.A. Windows shall be centered over cable terminations and allow for thermographic analysis of all cable terminations.
 - 3.11.B. IR windows shall be IRISS CAP-CT-12. All exceptions must be approved by University Electrical Engineering staff.
 - 3.11.C. **Exception:** IR windows are not required if switchgear is provided with hinged rear doors.
- 3.12. Warning signs and labels in accordance with NEC and OSHA regulations.
- 3.13. One N.O. and N.C. aux contact per switch or breaker that follows operation. Aux contacts shall be wired out to a terminal block on the outside of the switch enclosure with labels identifying the contact type. Terminal block shall be mounted in a box.
 - 3.13.A. Aux contacts shall be rated for the applied wetting voltage.
- 3.14. A mimic bus will be applied on the front of the switchgear by the University after installation by the contractor.
- 3.15. All power cable termination points shall be silver or tin plated. Termination of phase cables on bare copper is prohibited. This requirement does not apply to ground conductors.

4. Minimum Ratings

- 4.1. Nominal voltage: 13.8 kV
- 4.2. Maximum design voltage: 15 kV
- 4.3. Basic Impulse Level (BIL): 95 kV
- 4.4. Continuous Current: 600 A

- 4.5. Load Break Current: 600 A
- 4.6. Parallel or Loop Switching Current: 600 A
- 4.7. Short Circuit Withstand Current: 25 kA RMS Symmetrical
- 4.8. Momentary Current: 40 kA RMS Asymmetrical
- 4.9. Close and Latch Current: 40 kA RMS Asymmetrical

5. Nameplates

- 5.1. A stainless steel equipment rating nameplate shall be mounted on the exterior of the switchgear and shall contain the following information:
 - 5.1.A. Manufacturer's name
 - 5.1.B. The assembly or drawing number
 - 5.1.C. Operating (nominal) voltage
 - 5.1.D. Maximum design voltage
 - 5.1.E. Basic Impulse Level (BIL)
 - 5.1.F. Continuous and Load Break current
 - 5.1.G. Short circuit interrupting current
 - 5.1.H. Close and latch current
 - 5.1.I. Momentary current
- 5.2. A stainless steel fuse rating nameplate shall be mounted on each switch bay with a fuse and shall contain the following information:
 - 5.2.A. Name of the fuse manufacturer
 - 5.2.B. Fuse holder catalog number or style number
 - 5.2.C. Maximum fuse or fuse clip continuous current
 - 5.2.D. Fuse refill catalog or style number, ampere size, voltage rating, and short circuit rating.
- 5.3. Refer to Section 260553 for equipment identification nameplate requirements.

6. Automatic Transfer Functionality

- 6.1. Where medium voltage automatic transfer functionality is required of the switchgear, the A/E shall discuss the requirements with the University electrical engineering staff for further detail.

7. Pad-Mounted Switchgear

- 7.1. Pad-mounted switchgear is not allowed without approval from the U of M electrical engineering staff.
- 7.2. Pad-mounted switchgear shall be provided with a three phase, gang-operated switch for disconnection of each load served from the switch.

- 7.2.A. Use of load break fuses for switching loads is not permitted.
- 7.3. Where approved, pad-mounted switchgear shall be installed on a concrete equipment pad.
 - 7.3.A. Equipment pad shall extend a minimum of 1” above finished graded
 - 7.3.B. Equipment pad shall extend no more than 6” above finished grade, at the highest point.
 - 7.3.C. Pad shall extend no more than 6” beyond the edge of the equipment
 - 7.3.D. Pad shall include rebar reinforcement.
 - 7.3.E. Pad design must be approved by University Electrical Engineering staff prior to construction.
 - 7.3.F. Provide sleeves for all conduit penetrations in equipment pad. Do not pour conduits directly in to the equipment pad.
- 7.4. Pad-mounted switchgear shall be installed above a fiberglass box pad or switch spacer. Confirm selection with University Electrical Engineering Staff.
 - 7.4.A. Provide 6” of gravel in the bottom of the box pad.
 - 7.4.B. Switch spacers shall be provided by the switch manufacturer.

The box pad / spacer is intended to provide additional cable installation space.

END OF SECTION

26 18 16 MEDIUM VOLTAGE FUSES

1. General

- 1.1. Fuses and fuse clips shall be S&C expulsion type. NO EXCEPTIONS.
- 1.2. Fuse mountings shall be designed to be operated with a hot stick tool.
- 1.3. Provide three spare fuses or fuse refills of each size used.
- 1.4. All fuses shall be standard speed.
- 1.5. Switch shall be capable of being energized with the fuse in the open position.
- 1.6. Furnish and install a wall mounted spare fuse cabinet. Cabinet shall have a hinged door and shall be painted. The dimensions of the cabinet shall be a minimum of 36"W x 36"H x 12"D.
- 1.7. Fuse minimum ratings:
 - 1.7.A. Nominal voltage: 13.8 kV
 - 1.7.B. Maximum Design Voltage: 15 kV
 - 1.7.C. Short Circuit Interrupting Current: 25 kA RMS Symmetrical
- 1.8. Insulating barriers shall be provided between each fuse clip.

2. Fuse Sizing

- 2.1. The following fuse sizes shall be use for medium voltage building transformers:
 - 500 kVA = 30E
 - 750 kVA = 40E
 - 750/1000 kVA = 50E
 - 1000 kVA = 50E
 - 1000/1333 kVA = 65E
 - 1500 kVA = 80E
 - 1500/2000 kVA = 100E

END OF SECTION

26 22 00 LOW VOLTAGE TRANSFORMERS

1. General

- 1.1. Locate transformers in accessible, ventilated, cool, dry, clean areas.
 - 1.1.A. Where these conditions cannot be provided, specify transformers that are suitable for the environment.
- 1.2. Transformers shall comply with the Minnesota Energy Code, minimum efficiencies.
 - 1.2.A. For exceptions to the Energy Code, specify dry type transformers 25 kVA and above, for a maximum of 115 degrees C temperature rise above a 40 degree C ambient temperature, with a 220 degree C rated insulation system.

2. Construction

- 2.1. Winding material shall be aluminum or copper.
- 2.2. Sound levels shall be consistent with the use of the building areas adjacent to the transformer. Sound levels shall not exceed ANSI standards. In areas of very low ambient noise level such as libraries and reading rooms, use transformers with lower sound levels.

3. Installation

- 3.1. Install floor-mounted transformer on concrete pads.

END OF SECTION

26 24 13 SWITCHBOARDS

1. General

- 1.1. Provide a distribution class switchboard(s) for the building. The building main 480 volt or 208 volt switchboard shall be considered the service entrance point to the building and shall be specified as such.
- 1.2. Shall be designed to the latest applicable UL, ANSI and NEMA requirements.
- 1.3. The main secondary disconnect device to the building transformer shall incorporate a visible disconnect. This means it needs to be either a draw-out type circuit breaker or a bolted pressure switch with a viewing window. Mechanical indicators are not an acceptable alternate. If the switchboard is a main-tie-main arrangement, the tie breaker/switch shall have the same draw-out requirements as the main disconnect device.
- 1.4. Where draw-out circuit breakers are provided, specifications shall require a portable lifting and transport device compatible with the circuit breakers.
- 1.5. A switchboard with a main-tie-main arrangement shall be able to perform closed-transition-transfer between sources without interrupting service to the building. In addition, Kirk key mechanical interlocks shall be provided for the main-tie-main switches to prevent accidental paralleling of the mains. However, additional keys shall be provided as necessary to perform the closed transition switching.
- 1.6. Specify fault current ratings on the main-tie-main switchboards to be capable of withstanding the available fault current from both sources with both mains and the tie breaker closed.
- 1.7. A spare breaker of each frame size shall be specified in the contract documents, with the exception of the mains and tie breakers, which are interchangeable.
- 1.8. A secondary injection test device shall be specified in the contract documents for testing the tripping circuit of each breaker.
- 1.9. Specifications shall require complete physical layout, schematic, and wiring diagrams be submitted for review by the University electrical engineering staff. All control wiring shall be permanently labeled at both ends with opposite end wire markers that correspond to the wiring diagrams.
- 1.10. Specifications shall require that service switchboard final as-built drawings be provided in AutoCAD format.
- 1.11. 120 volt control power for the switchboard shall come from an internal control power transformer. The CPT shall not be located in the transformer enclosure.
 - 1.11.A. Control power for generator switchboards shall be from a separate emergency circuit.

Control power for generator switchboards must originate from a separate circuit to provide switchboard control power when the generator is off.

- 1.12. For maintenance and operations purposes, the University Electric Utilities department is responsible for all building electrical service infrastructure down to the main secondary disconnect device. The operation of downstream devices from the main secondary disconnect is the responsibility of the building facilities management.
- 1.13. The switchboard shall be located in an electrical room outside of the 3 hour rated high voltage vault in order to provide maintenance and operation access for building facilities management.
- 1.14. Provide one spare fuse for every 10 of each size used.
 - 1.14.A. This requirement applies to switchboard fused disconnects and control power fuses.
 - 1.14.B. Provide a minimum of three spare fuses of each size.

2. Switchboard Construction

- 2.1. All current carrying and grounding components shall be made of copper.
- 2.2. Include a continuous ground bus through the entire length of the switchboard. The ground bus shall be mounted in the front for front accessible only equipment and in the back for rear accessible equipment.
- 2.3. All service entrance switchboards shall include a full height section barrier between the service disconnect section and switchboard sections containing feeder and/or tie breakers/disconnects.
- 2.4. Circuit Breakers:
 - 2.4.A. The mains and tie breakers shall have the same frame size and shall be interchangeable.
 - 2.4.B. All circuit breakers shall have field replaceable, current sensing plugs.
 - 2.4.C. All circuit breakers shall have the minimum adjustable setting: Long time pickup (LTP); Long time delay (LTD); Short time pickup (STP); Short time delay (STD); Instantaneous (Inst). Where ground fault detection is required by code, all breakers (including main, tie and feeders) shall have adjustable ground fault pickup (GFP) and ground fault delay (GFD).
 - 2.4.D. Trip units for circuit breakers shall have LED indication on the front of the unit flagging the type of overcurrent trip that was detected. If the trip units have digital displays, there shall be external power to the trip units to allow them to display the full range of current through the breaker.
 - 2.4.E. The main and tie breakers shall have a 120V AC shunt trip device wired out to terminal blocks for future remote tripping.

- 2.4.F. Specify a minimum of two N.O. and two N.C. auxiliary contacts on the main and tie breakers wired out to terminal blocks for remote monitoring of the breaker open/close status.
- 2.5. Instrument Transformers:
 - 2.5.A. Reference 26 27 13 - Metering
- 2.6. Undervoltage/Phase-loss relay:
 - 2.6.A. Provide each main breaker position with a three-phase undervoltage/phase loss relay that is to be used for alarming purposes only.

The function of the relay is to provide a dry contact alarm for the University PSECC monitoring system, which will notify operators that there has been a loss of power in the building. Do not trip the main breaker with this relay.

- 2.6.B. The relay dropout setting must be adjustable down to 80 percent of nominal voltage.
- 2.6.C. The relay voltage sensing must be on the load side of the main breaker and must have a three pole disconnect switch for maintenance.
- 2.6.D. The relay outputs must be wired to terminal blocks for connection by the Division 23 controls sub-contractor.
- 2.6.E. Each relay shall be mounted in its respective **isolated** instrument compartment with an empty $\frac{3}{4}$ conduit installed from the instrument compartment to a junction box outside of the electrical room for connection by the Division 23 sub-contractor.
- 2.7. Surge Protective Device (SPD)
 - 2.7.A. Each substation shall be provided with a surge protective device.
 - 2.7.B. A means of disconnect shall be provided. Disconnect device shall be accessible without removing any covers.
 - 2.7.C. UL listed.
 - 2.7.D. Utilizes metal oxide varistor (MOV) technology.
 - 2.7.E. Shall be equipped with a surge counter display.
- 2.8. IR Windows
 - 2.8.A. Provide IR windows for thermographic analysis of each service disconnect cable termination.
 - 2.8.B. Windows shall be centered on cable terminations and provide a clear view of all terminations.

- 2.8.B.1. IR windows shall be IRISS CAP-CT-24. All exceptions must be approved by University Electrical Engineering staff.

END OF SECTION

26 24 16.13 PANELBOARDS

1. General

- 1.1. Flush mounted panelboards are not preferred. Provide surface mounted panelboards where possible.
 - 1.1.A. Provide four (4) spare 1 inch conduit stubs from flush panels into drop down ceiling space or other accessible space.
- 1.2. Panelboards shall not be installed in hallways, corridors or public spaces.
- 1.3. Maximum quantity of branch breakers per panelboard shall be 42.
- 1.4. **PROHIBITED:** Sub-feeds from one panelboard to another panelboard in a different area of a floor or on an entirely different floor. Sub-feeds are only allowed to neighboring panels that serve common loads.
- 1.5. **PROHIBITED:** Panelboards with feed-through connections from one panelboard to another panelboard in a different area of a floor or on an entirely different floor. Feed through connections are only allowed to neighboring panels that serve common loads.
 - 1.5.A. **Exception:** Facilities not used for research, medical treatment or meant for continuous operation.

Panelboard connections should be constructed so that it is not necessary to de-energize multiple floors / building areas to shut off a single panelboard.

2. Construction

- 2.1. Bus material shall be copper.
- 2.2. Ground bus shall be copper
- 2.3. Front trim shall be hinged.
- 2.4. Provide a latch, lock and key set on the door covering the circuit breakers.
- 2.5. Circuit breakers shall be bolt on type.
 - 2.5.A. Tandem circuit breakers are prohibited.
- 2.6. Where required for selective coordination, panelboards may be fusible type.
 - 2.6.A. Provide one spare fuse for every 10 circuits of each size. Provide a minimum of three spare fuses of each size.
- 2.7. Series rated panelboards are prohibited.
- 2.8. Furnish each panel with a clear, plastic covered, typed circuit schedule. The schedule shall identify circuits by the final room numbers.

- 2.8.A. Include the schedule for panelboards in the design documents.
- 2.8.B. The design document circuit schedule shall include the following information: Voltage; Phase/Wire; Main Bus Rating; Main Breaker/Lug Rating; Short Circuit Rating; Circuit Numbers; Branch Circuit Current Rating; Number of Poles; Load Description; Connected VA.
- 2.9. Furnish a nameplate with the panelboard ID. Include the operating voltage and equipment that the panelboard is fed from.

3. Fused Panelboards

- 3.1. Fused panelboards are acceptable, where required for selective coordination requirements.
- 3.2. Provide one spare fuse for every 10 fuses of each size. Provide a minimum of 3 spare fuses of each size.

END OF SECTION

26 24 19 MOTOR-CONTROL CENTERS

1. General

1.1. PROHIBITED:

- 1.1.A. Variable Frequency Drives (VFDs) installed in motor control centers
 - 1.1.B. Panelboards installed in motor control centers.
 - 1.1.C. Distribution transformers located in MCC. Control power transformers are permitted.
 - 1.1.D. Central control power transformer (CPT) for MCC. Provide one CPT per starter.
- 1.2. Design engineer shall give consideration to available arc flash mitigation technologies.

2. Construction

- 2.1. Bus material shall be copper.
- 2.2. Both horizontal and vertical bus shall be fully rated for the entire length of the bus. Tapered bus is prohibited.
- 2.3. Shall have a continuous ground bus.
- 2.4. Use of fuses instead of circuit breakers must be approved by University engineering staff
- 2.5. Specify thermally compensated thermal overloads
- 2.6. All indicator lights shall be LED type. Incandescent lamps are prohibited.
- 2.7. Provide hand/off/auto switch for each motor starter
- 2.8. Provide the following indicator lights:
 - 2.8.A. Motor Running – Red
 - 2.8.B. Motor Off – Green
 - 2.8.C. Auto – Amber
- 2.9. Minimum starter size: NEMA size 1

END OF SECTION

26 25 00 ENCLOSED BUS ASSEMBLIES

3. General

- 3.1. The use of busway is not preferred due to reliability issues and difficulty of finding future replacement parts.
 - 3.1.A. Cable bus is an acceptable alternative.
- 3.2. Where bus duct runs vertically through a floor, include curbs around the floor penetration.
- 3.3. **PROHIBITED:** Bus duct is not allowed to be used between the main building transformer (primary unit substation) and the main secondary disconnect.
- 3.4. Bus risers must have redundancy to allow for unplanned outages. Redundancy shall be a separate but nearby riser that can back energize the other riser.

4. Construction

- 4.1. Bus material shall be copper.
- 4.2. Shall have separate 50 percent ground bus. Plug-in devices shall also have an integral, built-in ground connection for attachment to the bus ground.
- 4.3. Shall be sprinkler proof where necessary.

END OF SECTION

26 26 53 ELECTRIC VEHICLE CHARGING STATIONS

1. General

- 1.1. **PROHIBITED:** Charging cords that must cross a walkway or sidewalk to connect to the electric vehicle
- 1.2. All charging cords must automatically retract.
- 1.3. Consult with BOTH Energy Management and Parking Transportation Services (PTS) about electric metering and payment requirements for charging stations.
- 1.4. Provide one spare conduit for all underground conduit installations.
- 1.5. All underground charging station conduits shall be 2" or larger
- 1.6. Level 2 charging stations shall use J1772 compatible connectors.
- 1.7. Level 3 charging stations must be approved by Energy Management and Parking Transportation Services
 - 1.7.A. If approved, level 3 charging stations shall provide both CCS and CHAdeMO compatible plugs.
- 1.8. Designer shall evaluate potential damage from snow clearing operations. Designer shall assume that sidewalk snow clearing shall be accomplished by a snow clearing vehicle, not hand shoveling.
 - 1.8.A. Include bollards or other means of protecting chargers, where required.

26 27 13 METERING

1. General

- 1.1. Where required by Minnesota B3 Guidelines, provide a meter to monitor building plug load energy consumption. The meter shall comply with deduct / energy code metering requirements.
- 1.2. Where required by the NEC, provide a meter to monitor building lighting system energy consumption and peak demand. The meter shall comply with deduct / energy code metering requirements.
 - 1.2.A. The design engineer shall indicate the maximum design lighting load on the building oneline.

2. Service Metering

- 2.1. Each main breaker position shall be equipped with a Schweitzer Engineering Laboratories, Inc. (SEL) meter.
 - 2.1.A. For typical building applications, specify the following SEL 735 meter part number: 0735BX00944EXXB4XX16101XX
 - 2.1.B. Confirm part number with University Energy Management Engineering Staff.
- 2.2. The specification shall specifically call out that the meter shall be registered to the University of Minnesota and not the contractor purchasing the equipment.
- 2.3. The meter and all associated devices shall be mounted on the door of a dedicated instrument compartment or within the compartment.
- 2.4. The top of the meter shall not be mounted higher than 72 inches up from the finished floor.
- 2.5. Control power to the meter shall be fused.
- 2.6. Voltage sensing wiring shall originate from the line side of the main breaker and shall be fused with a 3-pole disconnect switch.
- 2.7. Systems operating at 1,000V, and higher, shall use potential transformers (PT) in a grounded-wye configuration to reduce the voltage to 120 volts line-to-ground. Both the primary and secondary sides of the PT's shall be fused.
 - 2.7.A. Provide six spare fuses of each size.
- 2.8. Current sensing shall come from three current transformers (CT), with all six leads of the CT's wired to a shorting type terminal block.
- 2.9. The CT's shall be grounded at one point at the shorting type terminal block and the shorting strip on the terminal block shall not be used as the permanent jumper for the non-polarity CT wiring.
- 2.10. The CT ratio for the metering shall take advantage of the overload thermal rating and shall be discussed with the University electrical engineering staff.

- 2.11. One N.O. main and tie breaker aux contact shall be wired to an input on the respective meter for remote monitoring by the University SCADA system. The tie breaker aux contact can be wired to either main breaker meter.
- 2.12. One N.O. transformer temperature monitor alarm contact shall be wired to an input on the respective meter for monitoring by the University SCADA system.
- 2.13. If provided, main and tie breaker maintenance switches shall have one N.O. contact wired to an input on the respective meter for monitoring by the University SCADA system.
- 2.14. All spare inputs and outputs shall be wired to terminal blocks.
- 2.15. Double lugging of control wiring on the meter terminal blocks is not allowed.
- 2.16. Each meter shall be equipped with an Ethernet port for communications back to the University SCADA system.

3. Deduct / Energy Code Metering

- 3.1. Deduct / Energy Code Meters shall be EMON 5000 or SEL 735. Use of other meters requires prior approval by Energy Management.
- 3.2. Where warranted, EMON 5000 meters may monitor up to three separate loads, utilizing three separate current sensors. Discuss these applications with Energy Management, where applicable.
- 3.3. Provide an Ethernet jack and associated cable for each deduct / energy code meter.
 - 3.3.A. For typical applications, specify the following meter part number:
 - 3.3.A.1. SEL 735: 0735BX00944EXXB4XX16101XX
 - 3.3.A.2. EMON 5000: E50-*****-R06KIT
 - 3.3.A.2.a. ***** varies depending on meter current and voltage rating.
 - 3.3.B. Confirm meter part number with University Energy Management Engineering Staff.
- 3.4. Deduct / Energy Code Meters shall comply with the following:
 - 3.4.A. Utilize Modbus protocols.
 - 3.4.B. Each meter shall be TCP/IP addressable and provided with an integral Ethernet port.
 - 3.4.C. EMON meters installed on system operating above 120/208V, shall be provided with a disconnect switch located external to the meter.
 - 3.4.C.1. Disconnect switch shall be an enclosed rotary disconnect. Eaton/Bussmann ER1-16N3PB or similar.
 - 3.4.C.2. The disconnect switch shall be mounted adjacent to the meter and clearly identified as the incoming voltage disconnect.

3.4.C.3. Provide a warning label for the meter, indicating the operating voltage of the meter.

3.4.D. Systems operating at 1,000V or higher shall use potential transformers (PT) in a grounded-wye configuration to reduce the voltage to 120 volts line-to-ground. Both the primary and secondary sides of the PT's shall be fused.

3.4.D.1. Provide one spare fuse for every 10 fuses of each size.

3.4.D.2. Provide a minimum of six fuses of each size.

4. Metering Instrument Transformers:

4.1. Potential Transformers:

4.1.A. PT accuracy shall be 0.6 for X burdens.

4.2. Current Transformers:

4.2.A. Specify a minimum thermal rating of 1.5.

4.2.B. CT metering accuracy shall be a minimum of 0.6 at a burden B-0.9

4.2.C. CT minimum relay accuracy shall be:

4.2.C.1. Up to 50:5 C20

4.2.C.2. 75:5 thru 300:5 C50

4.2.C.3. 400:5 thru 1000:5 C100

4.2.C.4. 1200:5 and higher C200

END OF SECTION

26 27 26 WIRING DEVICES

1. General

- 1.1. Minimum quality for devices shall be specification grade.
- 1.2. General purpose wiring devices shall be brown or gray.

2. Receptacles

- 2.1. Receptacles and switches shall be screw-clamp type and rated for 20 amps at their operation voltage.
 - 2.1.A. EXCEPTION: Connectorized pigtail receptacles are permitted. (Pass & Seymour Plugtail or similar).
- 2.2. Provide duplex GFCI receptacle mounted 42 inches above each floor in all pipe spaces, pipe shafts, duct shafts, attic space, tunnels, garages, maintenance spaces, and mechanical equipment spaces.
- 2.3. Provide 3 phase, 60 amp, 208 volt rated welding receptacles in mechanical spaces.
- 2.4. Receptacles on emergency and standby power circuits shall be identified with an “Emergency” label or colored red.
- 2.5. Receptacles with an isolated ground shall be labeled with “Isolated Ground”.
- 2.6. Receptacles must be provided on the ground floor of all stairwells and elevator lobby banks in parking facilities.

3. Floor Maintenance Equipment Receptacles

- 3.1. For corridors, large assembly areas and other areas where floor maintenance equipment is used, locate receptacles so that a 45-foot cord will reach any part of the floor.
- 3.2. Each receptacle location shall have a duplex, 120 volt, 20 amp outlet, served by two circuits.

The intent of this requirement is to prevent overloading circuits when large floor cleaning equipment is used to clean corridors / hallways. This has been particularly problematic in buildings with floors requiring polishing. This may not be required for carpeted or smaller hallways and corridors.

4. Switches

- 4.1. Toggle and key type wall switches for lighting loads shall be quiet type, rated 20 amps and 120 or 277 volts.
- 4.2. Switches in high voltage electric vaults shall be 3-way type with illuminated toggles.

5. Wall Plates

- 5.1. Wall plates shall be satin finish stainless steel.
 - 5.1.A. No. 430 magnetic stainless steel in non-corrosive locations.
 - 5.1.B. No. 302 non-magnetic type stainless steel in corrosive locations such as pools and laboratories.

6. Controlled Receptacles

- 6.1. Receptacles shall not be controlled, except in locations require by Minnesota Energy Code.
- 6.2. Receptacles that are scheduled shall be controlled through the building automation system.
 - 6.2.A. Scheduled receptacles must be provided with a local over-ride button / switch. The override function shall last no more than 2 hours.
- 6.3. Receptacles using sensor control shall use occupancy type sensors.
- 6.4. Receptacle controllers may not be connected to other receptacles or lighting controllers outside of the room containing the receptacle – except the building automation system.

END OF SECTION

26 28 16 ENCLOSED SWITCHES AND CIRCUIT BREAKERS

1. General

- 1.1. Piggy-back or tandem circuit breakers are prohibited.
- 1.2. Switch and circuit breaker enclosures located in corrosive areas, such as pools, laboratories, and cooling towers, shall be made of stainless steel.

2. Enclosed Switch Construction

- 2.1. Shall be heavy duty.
- 2.2. Specify rejection type fuse holders where current limiting fuses are used.
- 2.3. Spare fuses must be specified with fused switches.
- 2.4. Switch must be lockable in the open position.

END OF SECTION

26 29 13 ENCLOSED CONTROLLERS

1. General

- 1.1. In areas where there are a reasonable number of three-phase motors, provide a motor control center.
- 1.2. Motors 100 horsepower or larger shall be started with a reduced voltage starter, a wye-delta starter, an electronic soft starter, or a VFD.
 - 1.2.A. A motor starting analysis shall be submitted to the University electrical engineering staff that verifies the system voltages will not dip below 90 percent upon the starting of the largest motor under system full load conditions.
 - 1.2.B. Consideration shall be given to using a 4160-volt system for motors 1,000 horsepower or larger.
- 1.3. Motors controllers shall be NEMA rated.
- 1.4. Control circuit voltage shall be 120 volts or less.
- 1.5. Each motor starter shall have its own control power transformer.
- 1.6. Duplex Pumps: Each unit shall be labeled and have its own on/off control. Incorporate an alternator, software or mechanically, that allows it to stop and automatically restart via the building automation system. Include an auto-backup feature.
- 1.7. Specify hand/off/auto (HOA) automatic control for fan motors operated via the building automation system.
- 1.8. Specify each starter to include a red indicating LED light for “Running” status and a green LED indicating light for “Stop” status.
- 1.9. Incorporate a minimum of four auxiliary contacts (2 N.O. and 2 N.C.) in each starter.
- 1.10. Include a schedule in the design drawings for the motor control center.

END OF SECTION

26 29 23 VARIABLE FREQUENCY MOTOR CONTROLLERS

1. General

- 1.1. Minimum level of performance shall be compliant with IEEE 519 criteria for a general distribution system, modified as appropriate for the specific project.
 - 1.1.A. The harmonic analysis shall encompass the entire electrical system on a per voltage basis. A harmonic analysis of just the VFD's being supplied by a vendor is not acceptable.
 - 1.1.B. Harmonic mitigation equipment shall be applied as required to meet IEEE 519 requirements.
- 1.2. All drives 25hp and larger shall be specified as low harmonic type (ITHD < 10%).
- 1.3. Where specifications permit high-carrier frequency or IGBT output devices, address requirements for motor over-voltage surge protection as part of the design.
- 1.4. **PROHIBITED:** VFDs with integral bypass.
- 1.5. **PROHIBITED:** VFDs rated less than 100hp, with integral disconnects. Provide separate disconnect switch, located near each VFD.
- 1.6. Clearly assign responsibility for VFD/motor compatibility in the specifications.
- 1.7. Install VFDs as close as possible to the motor.
- 1.8. Specify the following VFD performance features:
 - 1.8.A. Minimum efficiency at full load: 95 percent.
 - 1.8.B. Minimum displacement PF at full load: 95 percent.
 - 1.8.C. Adjustable thermal overload protection: Class 10, 20 and 30.
 - 1.8.D. Programmable minimum frequency.
 - 1.8.E. Overload capability: 110 percent for variable torque application, and 140 percent for constant torque applications.
 - 1.8.F. Carrier frequencies (in excess of 3,000 Hz) shall be adjustable.
 - 1.8.G. Automatic restart and ability to start into rotating motor.
 - 1.8.H. Ability to operate the VFD with the motor disconnected for trouble-shooting and maintenance..
 - 1.8.I. Integral closed loop PID controller.
 - 1.8.J. English language display. Alpha-numeric codes are not acceptable.
 - 1.8.K. RS485 serial communication and Ethernet port for communication to the building DDC system.
 - 1.8.K.1. Available protocols shall be Modbus and BacNet.

- 1.8.L. Field wiring terminal boards (identified on the drawings) for all customer connections.

END OF SECTION

26 31 00 PHOTOVOLTAIC COLLECTORS (SOLAR PANELS)

1. General

- 1.1. All PV arrays must be approved by Energy Management
- 1.2. PV arrays require an interconnection agreement with the campus utility, typically Xcel Energy. This interconnection agreement shall be the responsibility of the A/E. Contact Energy Management with questions regarding the process / forms.
- 1.3. When evaluating the payback of solar arrays on campus, contact Energy Management for current electric rates.
 - 1.3.A. Note that the University of Minnesota Twin Cities Campus is subject to time of use billing.
- 1.4. PV arrays shall be provided with a dedicated electric meter. The electric meter shall meet all requirements of SERVICE metering, as defined in section 26 27 13.
- 1.5. All PV array inverters shall be provided with a general alarm output contact. The alarm shall be connected an input on the PV array electric meter.
- 1.6. When installed load side of a building service disconnect, the A/E shall evaluate the array output compared to the building MINIMUM load. If the PV array output is likely to exceed the building minimum demand, bi-directional metering at the building service shall be provided.
 - 1.6.A. Discuss bi-directional metering options with Energy Management.
 - 1.6.B. If PV array output exceeds the minimum building load by more than 50kW, the impact of the array on the campus distribution system must be approved by Energy Management.
- 1.7. When installed load side of a building service disconnect, PV arrays shall be provided with a disconnect located within sight of the building service.
- 1.8. The system inverters shall not exceed 5% current THD at rated output.
- 1.9. A/E shall verify the PV system is compatible with the building roof and will not affect the roof warranty.
- 1.10. The A/E shall evaluate the impact of the system on building short circuit currents and verify no equipment ratings will be exceeded.
 - 1.10.A. Where applicable, A/E shall update the building short circuit current and arc flash hazard studies to include contribution of the solar array.
- 1.11. PV string home-runs shall be labeled and color-coded: red for positive conductors and black for negative conductor
- 1.12. PV string home-runs shall be megohm meter tested
- 1.13. PV string home-runs shall be tested for expected Voc and polarity.
- 1.14. PV string home-runs shall have string IV testing.

- 1.15. Provide a commissioning report showing the results for each string along with the expected results.

END OF SECTION

26 32 13 ENGINE GENERATORS

1. General

- 1.1. Generator and prime mover shall be direct-coupled.
- 1.2. Generators shall not be considered for peak shaving, unless approved by the University.
- 1.3. Generators used for emergency systems shall have an on-site fuel source and a minimum run time of 6 hours.
 - 1.3.A. Generator run times may be required to be extended based on specific requirements of the facility, research certifications or user requests. The A/E shall be responsible for determining any needs for extended run times.
 - 1.3.B. Generators may have the option of using natural gas for a fuel. The A/E is responsible for determining if the natural gas supply is sufficient for the generator and will not impact other natural gas loads on the same service line within the building.
- 1.4. Specify a method of damping vibration and noise to acceptable levels. Generators located above classrooms, labs, study areas, libraries, etc. shall be given special consideration for vibration and noise. The A/E shall submit the methods for how vibration and noise will be mitigated.
- 1.5. Generators shall be a four wire grounded source.
- 1.6. Auxiliary alarm contacts shall be provided as follows:
 - 1.6.A. “Engine Run” contact to be provided and wired to the building DDC system for annunciation to the University PSECC department by the DDC contractor.
 - 1.6.B. “Engine Run”, “Engine Trouble”, “Engine Shutdown” and “Low Fuel” contacts to be provided for the University electrical SCADA system. Responsibility for raceway and wiring to be reviewed with the University electrical engineering staff.
 - 1.6.C. Reference Figures: ‘Typical SCADA and BAS Monitored Points’ for additional information.
- 1.7. Provide auxiliary contacts for the battery charger alarm(s). The alarm shall be wired to the University electrical SCADA system or the generator control panel, as part of the “Engine Trouble” alarm. Responsibility for raceway and wiring to be reviewed with the University electrical engineering staff.
- 1.8. Generator electrical output shall be metered with a University approved meter. The meter shall be integral to the generator distribution equipment or separately mounted on a University approved box. The meter shall have an Ethernet port and shall utilize DNP or Modbus protocol.

- 1.8.A. Installations which cannot be practically metered shall provide a generator controller with DNP or Modbus protocol communications and an integral Ethernet connection. The generator controller shall be networked back to the University SCADA system.
- 1.9. Voltage and frequency steady state regulation, electronic speed regulation and transient performance shall be specified for all classes of load and load rejection.
- 1.10. Provisions for connection of an owner furnished, portable load bank shall be provided for code required testing and maintenance.
 - 1.10.A. The connection shall accommodate a portable generator to be used when the permanent generator is disabled.
 - 1.10.B. The connection point shall be at the exterior of the building, at grade or a location accessible by a portable generator.
 - 1.10.C. Provide one Cam-Lock receptacle per 400A of capacity. Connectors shall be paralleled to achieve required ampacity.
 - 1.10.C.1. Any connectors supplied by less than 400A rated conductors shall be field labeled with the rated ampacity.
 - 1.10.D. The connection cabinet shall be pad-lockable. Do not provide integral keyed latch.
 - 1.10.E. Provide portable generator starting contact connection point and selector switch to allow building transfer switches to start a portable generator.
 - 1.10.E.1. Selector switch shall issue an alarm to the building automation system when the portable generator is selected.
 - 1.10.F. Provide a single 20A, 120V receptacle and a single 30A, 208V, 3 wire receptacle (NEMA 14-30R) next to the connection point.
- 1.11. Refer to Division 23 for general mechanical ductwork and piping requirements. All generator ventilation systems and louver controls must be powered by the emergency power system.
 - 1.11.A. Note that motor operated louvers used for generator supply/return/exhaust must fail open per NFPA 110. Use of fire dampers in these ducts is prohibited.
 - 1.11.B. Generator supply, return and exhaust air shall be directly from the outside or through a 2 hour fire rated duct per NFPA 110.
 - 1.11.C. Pneumatic actuation of louvers is prohibited.
- 1.12. The generator must be segregated from the normal power system per the Minnesota State Fire Code. The generator shall be installed in a separate 2 hour fire rated room. No equipment, except that serving the room, shall be installed in this space. Transfer switches may be installed in this space.

- 1.13. Generators mounted in outdoor enclosures with belly tanks must have a maintenance platform around all sides for access into the enclosure.
- 1.14. Generators installed indoors, with the control panel mounted higher than 72” must provide a platform for accessing the control panel.
- 1.15. Generators installed inside a building must be provided with a crankcase breather / ventilation manager to reduce engine blow-by.
- 1.16. Provide a generator radiator coolant level sight glass or other means to visually assess the coolant level without opening the radiator cap.
- 1.17. Generators serving fire pumps shall be provided with an input contact that disables all generator safety shutdowns, except over-speed, per NFPA 20. The input shall only be energized when the fire pump is running while on emergency power.

2. Fuel Oil Systems

- 2.1. Fuel oil tanks must have spill containment and shall have a means for visually verifying fuel oil level in addition to the mechanical or electronic fuel level indicators.
- 2.2. Day tanks must have a mechanical float gauge in place of or in addition to the electronic fuel gauge.
- 2.3. Fuel oil transfer systems must be designed with a fill tank and pump (at grade) at which allows fuel to be poured into the tank and then pumped up to the day tank. In addition, there shall be a dry-lock connector for a larger fuel truck to pump up to the day tank via a bypass line around the pump.
- 2.4. Isolation valves must be installed on the fuel oil transfer system to allow for pump maintenance without having to drain the system.

A means for pumping the fuel out of the day tank and back to the head end of the fuel oil transfer system must be provided because the life of very low sulfur fuel oil is limited and requires it to be periodically replaced.

- 2.5. Fuel oil coolers shall be provided as determined by the engine generator manufacturer.
- 2.6. Day tanks shall be sized to allow the generator to run for a minimum of 2 hours.

3. Emissions

- 3.1. Generators shall meet all relevant Minnesota and Federal Pollution Control Agency requirements for emission control and reduction.
- 3.2. All new generators must be submitted for permitting to the University Department of Environmental Health and Safety (DEHS). The A/E is responsible for filling out the necessary information on the engine generator permit application before submitting it to DEHS.

- 3.2.A. Depending on the size and use of the generator, construction of the building may not be allowed until the permit has been submitted and approved by the Minnesota Pollution Control Agency (MPCA). Please consult with DEHS for guidance.
- 3.2.B. All generator exhausts piping shall be located to disperse exhaust fumes and noise without affecting the normal functions of the building and surrounding site. Ensure that exhaust will not be re-entrained by nearby air intakes, including adjacent buildings.
- 3.2.C. Confirm with DEHS that exhaust models are in compliance with ambient air quality standards before determining final design. In general, exhaust stacks must be located approximately 10 feet above the highest roofline to disperse the exhaust and avoid building downwash, which can cause ambient air quality problems. The ambient air quality standards are listed in Minnesota Rules 7009. Exceptions to the 10 foot rule must be reviewed and approved by DEHS who will provide modeling for compliance with ambient quality air standards.

4. Testing

- 4.1. Full load testing required upon initial installation of the engine generator set. Specify a full startup and commissioning of the emergency generator by the generator vendor, including a full load test for the specified run time. This test must be run after the generator room systems are installed and operational (e.g. louvers, ventilation, doors, etc.).
- 4.2. Testing shall comply with the requirements of NFPA 110
- 4.3. Generator output circuit breaker(s) shall be tested. Generator manufacturer shall remove the breaker(s) to allow primary injection testing and reinstall the breaker(s) after testing is complete.
- 4.4. The generator manufacturer shall
 - 4.4.A. Demonstrate the functionality of all generator alarms / shutdowns.
 - 4.4.B. Demonstrate the functionality of all remotely monitored alarm / warning output contacts.
 - 4.4.C. Demonstrate the operation of circuit breaker shunt trip functionality (if applicable).
- 4.5. Provide a 1,000 V DC Megger / polarization index test of the generator stator and rotor windings. Generator manufacturer shall disconnect all sensitive wiring from the rotor / stator and reconnect the wiring after the test is complete.
- 4.6. Provide a winding resistance test of the generator stator and rotor windings. Generator manufacturer shall disconnect all sensitive wiring from the rotor / stator and reconnect the wiring after the test is complete.

END OF SECTION

26 33 53 STATIC UNINTERRUPTIBLE POWER SUPPLY

1. General

- 1.1. Possible requirements may include building automation system applications, server rooms, and emergency systems.
 - 1.1.A. Redundant UPS systems for large data centers or server rooms shall be considered.
- 1.2. Stationary, hardwired UPS equipment shall be an on-line type system that rectifies the incoming house power to a DC bus and converts it back to AC.
- 1.3. Include integral bypass/isolation circuit breakers for all stationary, hardwired UPS equipment. Bypass designs must be reviewed and approved by the University for future replacement capabilities.
- 1.4. The UPS shall be specified to be capable of staying online during an automatic transfer switch transition from normal power to generator, and from generator to normal power.
- 1.5. Include one normally open and one normally closed general alarm contact wired out to the building DDC system for remote monitoring by our PSECC department.
- 1.6. The option for a high efficiency UPS shall be considered and reviewed by the University.
- 1.7. UPS systems required to comply with NFPA 111 shall meet the following requirements:
 - 1.7.A. Provide means for connecting alternate emergency power source when UPS system is inoperable due to equipment repair or maintenance, as require by NEC.
 - 1.7.A.1. Reference Figures: 'UPS Alternate Source Connection Schematic' for additional information.
 - 1.7.B. **Prohibited:** Installing UPS in the same room as the building service disconnects.
 - 1.7.C. UPS room shall be protected with pre-action or gaseous fire protection systems.
 - 1.7.D. Provide a load bank connection, sized to match the UPS rated output.
 - 1.7.D.1. Load bank connection shall use 400A Cam-Lock receptacles, paralleled as required.
 - 1.7.D.2. Any connectors supplied by less than 400A rated conductors shall be field labeled with the rated ampacity.
 - 1.7.D.3. Give consideration to the where the UPS load bank will be located. Verify that the heat generated by the load bank will not be problematic.

- 1.7.E. Provided with auxiliary contacts as follows:
 - 1.7.E.1. “On Battery”
 - 1.7.E.2. “General Warning
 - 1.7.E.3. “UPS Failure”
 - 1.7.E.4. All alarm contacts to be wired to the building DDC system for annunciation to the University PSECC department by the DDC contractor.

2. Batteries

- 2.1. Batteries shall be “hot-swappable” so the UPS can stay on-line while batteries are being replaced.
- 2.2. Wet cell batteries, if used, shall have a clear case with high and low acid levels lines extending around all sides of the case.
 - 2.2.A. Provide means for testing individual cell specific gravity.
 - 2.2.B. Provide flame arrester caps.
 - 2.2.C. Each case shall indicate the nominal cell voltage.
 - 2.2.D. Each case shall indicate the nominal and critical specific gravity.
 - 2.2.E. Each case shall be marked with the date of manufacture.
- 2.3. Batteries on racks or in cabinets shall be accessible for testing and verifying torque for individual cells or unit terminals. Vertical space above batteries shall be a minimum of 6 inches for dry/maintenance free batteries and a minimum of 18 inches for wet cell batteries.
 - 2.3.A. Batteries shall not be placed higher than 6 feet above the finished floor.
 - 2.3.B. Provide equipment for assisting in removal of cells when total weight of individual cell blocks exceeds 75 pounds.
- 2.4. Each cell shall be numbered for maintenance records.
- 2.5. Batteries shall require a straight pro-rated replacement agreement or better from the battery manufacturer.
- 2.6. Specify a full load test of the UPS battery system by the UPS vendor.
- 2.7. Automatic battery monitoring systems shall be considered and discussed with the University.

3. Harmonics

- 3.1. The design shall comply with IEEE 519 requirements at the point of common coupling. Other harmonic generating loads (e.g. VFD’s) shall be included in the calculation.
- 3.2. Specify the limits for harmonics, the requirements for the input filter, and a requirement for field testing to verify compliance with the specifications.

4. Testing

- 4.1. Full load testing required upon initial installation of the UPS system. Specify a full startup and commissioning of the UPS by the vendor, including a full load test for the specified run time. This test must be run after the UPS room systems are installed and operational (e.g. louvers, ventilation, doors, etc.).
- 4.2. Testing shall comply with the requirements of NFPA 111 – 2010
- 4.3. UPS output circuit breaker(s) shall be tested. UPS manufacturer shall remove the breaker(s) to allow primary injection testing and reinstall the breaker(s) after testing is complete.
- 4.4. The UPS manufacturer shall
 - 4.4.A. Demonstrate the functionality of all UPS alarms / shutdowns.
 - 4.4.B. Demonstrate the functionality of all remotely monitored alarm / warning output contacts.
 - 4.4.C. Demonstrate the operation of circuit breaker shunt trip functionality (if applicable).

END OF SECTION

26 36 23 AUTOMATIC TRANSFER SWITCHES

1. General

- 1.1. All current carrying components shall be copper.
- 1.2. Breakers for emergency ATS shall be in a separate enclosure from other ATS circuit breakers.
- 1.3. Optional Standby ATS rated at 1,000 amps or more must have ground fault protection on a standby source breaker. Ground fault indication is not sufficient.
- 1.4. Consider closed transition transfer switches when supplying optional standby loads such as research or ventilation equipment.
 - 1.4.A. All closed transition transfer switches must be submitted to Xcel Energy for approval. The A/E is responsible for filling out the Xcel application. The University will submit the application and pay the fees.
 - 1.4.B. The closed transition transfer ATS shall be equipped with an extended parallel relay that will trip the upstream disconnect device in the event the ATS is stuck in the parallel position. The upstream disconnect will need to be equipped with a shunt trip mechanism.
 - 1.4.C. Closed transition ATS shall not require batteries for proper installation during transfers.

VFDs and similar sensitive loads will often trip off or not restart after open transition transfers, even when ATSs are equipped with an in-phase transfer capability.

- 1.5. Consider bypass/isolation for transfer switches when supplying research loads.
 - 1.5.A. Bypass / isolation shall permit maintenance / repair of transfer switch without exposing personnel to energized power conductors.

Repairs / maintenance of transfer switches without bypass isolation requires extended power interruptions to the supplied equipment. Highly sensitive research equipment or ventilation equipment which cannot tolerate such outages should be provided with a bypass / isolation option to allow maintenance / repairs without interruption to the loads. University safety policies do not permit working on / near energized power conductors. Bypass / isolation should permit repairs / maintenance without exposing personnel to an arc flash / electrocution hazard.

- 1.6. A dedicated ATS shall be used for all Optional Standby loads and shall not be shared with legally required loads. Specify normally closed load shed contacts for future use.
- 1.7. ATS shall have fully rated short circuit ratings that meet the system available fault current.
 - 1.7.A. **Prohibited:** Series rating with circuit breakers or fuses.
- 1.8. Provide a minimum of two sets of auxiliary form C contacts (rated for the appropriate wetting voltage) to indicate normal and emergency transfer switch positions.
 - 1.8.A. One set of contacts must be wired to the building DDC system for status indication back to the University PSECC department.
- 1.9. All ATS's, including a fire pump ATS, shall have a generator start command contact.
- 1.10. Segregate emergency and legally required standby system ATS per the Minnesota State Fire Code and the NEC.
- 1.11. Fire pump controllers with integral transfer switches shall provide one form C contact indicating when the fire pump is running (NOT when the transfer switch operates).

END OF SECTION

26 41 00 FACILITY LIGHTNING PROTECTION

1. General

- 1.1. The A/E shall perform a risk assessment and make recommendations to the University as to the merits of a lightning protection system.
 - 1.1.A. The Risk assessment shall be compliant with NFPA 780.

The intent of this requirement is to ensure that, when specified, lightning protection systems are warranted. An exception request is not required if the A/E conducts an evaluation of the site and determines lightning protection is not needed.

- 1.2. Lightning protection components and system must be UL listed and in compliance with Lightning Protection Institute and the NFPA requirements.
- 1.3. If installed, the lightning protection system must carry the Master Label as defined by the Underwriters Laboratory.

END OF SECTION

26 43 13 SURGE PROTECTIVE DEVICE (SPD)

1. General

- 1.1. All building low voltage service equipment shall be equipped with a Surge Protective Device (SPD).
- 1.2. There shall be a disconnect device between the SPD and main bus. The disconnect shall be in an accessible location and shall not require an outage of the equipment to operate.
- 1.3. The SPD shall be compliant with the latest edition of UL 1449.

END OF SECTION

26 50 00 INTERIOR LIGHTING

1. General Requirements

- 1.1. **PROHIBITED:** Using a single circuit for all lights on a floor.
- 1.2. The Illuminating Engineers Society of North America (IESNA) Lighting Handbook, current edition, shall be used as a standard for lighting levels. Provide a spreadsheet showing all room names and numbers along with target illumination levels.
- 1.3. Provide two (2) hard copies, or one electronic copy of a light fixture cut-sheet booklet with any submittal showing lighting layouts. The booklet shall be in color with all fixture types clearly identified and include the light fixture schedule as well as proposed lighting controls.
- 1.4. Include the luminaire fixture schedule within the drawings, not within the specifications. As-built drawings shall include final luminaire information.
- 1.5. Submit one (1) copy of software generated lighting calculations of most interior spaces, during the DD design phase, to Energy Management for review. The use of “typical” rooms shall be acceptable except when daylight contribution is a factor for lighting controls. Show calculations for each space without daylight contribution as well as with daylight contribution and lighting controls. All levels shall be legible and shown on a scale drawing. All pertinent calculation parameters, (i.e. Avg, Min, Max, Avg/Min, Max/Min) shall be indicated and highlighted where non-IES compliant. Energy Management will provide direction and variance where deemed adequate. Utilize AGI-32 full calculation mode or a similar program, as approved by Energy Management.

2. Light Emitting Diode (LED) Lighting

- 2.1. LED lighting shall be considered the basis of design for all interior applications.
- 2.2. All LED fixtures shall be DesignLights Consortium (DLC) qualified. Qualified fixtures can be found at: <https://www.designlights.org/qpl>
 - 2.2.A. **EXCEPTION:** Specialty / Decorative lighting not qualified by DLC.

The DesignLights Consortium does not currently qualify specialty lighting such as decorative lighting, cove lighting, and commercial downlights (a full list of ineligible luminaire types is available on their website). Therefore, it is not possible to use DLC qualified LED luminaires for these types of specialty lighting.

- 2.3. All LED fixtures shall be sourced from a company with no less than five years experience manufacturing LED lighting products
- 2.4. LED fixtures shall be 50,000+ hour rated average life

- 2.5. Specify 0-10V dimming control. Line voltage dimming of LED lighting is prohibited.
- 2.6. All fixtures shall maintain a minimum of 70% rated lumen output (L70) at 50,000 hours.
- 2.7. Typically incorporate a 3500 - 4500 degree Kelvin temperature and a minimum CRI of 80.
- 2.8. Flicker shall not exceed 5%

3. Miscellaneous Lighting Types

- 3.1. **PROHIBITED:** Incandescent lamps; unless specifically approved by the University electrical engineering staff.
- 3.2. **PROHIBITED:** Low pressure sodium lamps.
- 3.3. **PROHIBITED:** Mercury vapor lamps due to low efficacy.

4. High Intensity Discharge (HID) Lighting

- 4.1. LED lighting is preferred. Where used, HID lighting shall comply with the following:
 - 4.1.A. To prevent hazardous failure mode where metal halide lamps are used, make provisions for switching off luminaires a minimum of 15 minutes per week. Review this requirement with the University.
 - 4.1.B. High power factor regulator-type high intensity discharge (HID) ballasts that have a minimum power factor of 90 percent over the life of the lamp shall be specified. Also specify that the ballasts provide less than 1 percent variation of lamp wattage per percent of line voltage.
 - 4.1.C. HID ballasts for outside applications shall have a minimum starting temperature of -40 degrees F.
 - 4.1.D. Metal Halide Lamps and ballasts shall be pulse start, where available for specified wattages, and rated for "open" fixtures.
 - 4.1.E. For lensed metal halide luminaires, the lenses shall have tempered glass or high-impact safety lenses.
 - 4.1.F. Where HID luminaires are used indoors, they shall be of the low sound level with encapsulated ballasts, or electronic ballasts when available for specified wattages.

5. Fluorescent Lighting

- 5.1. **PROHIBITED:** Fluorescent lighting; unless specifically approved by the University electrical engineering staff. LED lighting shall be the basis of design for all interior lighting applications.
- 5.2. When fluorescent lighting is approved, the design shall include LED lighting as an alternate through project GMP. At time of GMP, perform a total life-cycle cost analysis using contractor pricing for LED option.

- 5.3. Fluorescent lighting must conform to the following requirements:
- 5.3.A. An in-line luminaire disconnect connector shall be used. The lighting manufacturer shall also provide a “wire nut” connection on the load side of the disconnect, to facilitate ballast replacement.
 - 5.3.B. Minimize the use of different lamp styles and wattages. Maximize the use of the 48 inch T8 lamp as this source has the best combination of efficiency, life, and low cost.
 - 5.3.C. Linear fluorescent lamps shall be the T-8, 25-watt, rapid-start, 2400+ initial catalog lumens, 30,000+ hour rated average life with instant start ballasts based on 3 hour operating cycle. The use of linear T-5 high-output fluorescent lamps is allowed where design applications exist, after it is approved by Energy Management. Compact fluorescent lamps shall be triple-tube style, 32W for down-lights and 18W for wall sconces. Coordinate other lamp wattages and styles with Energy Management. All fluorescent lamps will typically incorporate a 4100 degree Kelvin temperature and a minimum CRI of 80-86. Qualifying T8, 48 inch linear lamps are as follows:
 - GE Ecolux: F32T8/25W/SPX41/ECO
 - Philips Energy Advantage: F32T8/ADV841/XEW/ALTO 25 WATT
 - Sylvania Ecologic3: FO32/25W/841/XP/SS/ECO3
 - 5.3.D. Contractor shall obtain all similar lamp types through one source from a single manufacturer.
 - 5.3.E. Lamp Orientation: All lamps shall be specifically rated for the burn position in which they are used.
 - 5.3.F. All fluorescent lamps on dimming ballasts shall be burned in at full brightness for 100 hours (or as required by the lamp manufacturer) continuously prior to any dimming. Bypass local control as necessary to accomplish this task.
 - 5.3.G. Medium and high bays in mechanical spaces, loading docks, shops, lobbies, etc. shall take into account lamp life, lamp replacement, and controllability. Investigate the use of T8 fluorescent lamps (with high ballast factor ballast) versus T5HO in these applications, and discuss options with Energy Management.
 - 5.3.H. Fluorescent ballasts shall be “premium” efficiency, electronic, CBM and ETL approved with a sound rating of A. Ballast shall also be Class P, thermal cut-out switch, rated where required by U.L. Investigate use of high or low ballast factor as part of the illumination calculations. Linear ballasts shall be as follows:

- 5.3.I. PRS (programmed rapid start ballast) – use with occupancy sensors or frequent switching applications.
- Advance “Optanium”
 - GE “UltraStart”
 - Sylvania “PROStart”
- 5.3.J. IS (instant start ballast) – use with manual switched lighting and unswitched emergency luminaires.
- Advance “Optanium”
 - GE “UltraMax”
 - Sylvania “QHE”
- 5.3.K. Provide label sticker on each luminaire ballast chamber (in 1/8” lettering) to read either “ V; Instant-Start; Ballast Factor” or “ V; Program-Start; Ballast Factor” (insert the voltage and ballast factor in each underlined space). As an example, label might read “120V; Program Start; 0.88 Ballast Factor.”
- 5.3.L. Fluorescent ballasts for outside applications or in areas where ambient temperature is lower than 50 degrees F shall have a minimum starting temperature of -20 degrees F.
- 5.3.M. Luminaires mounted in areas that are difficult to access shall have remote ballasts.
- 5.3.N. Remote mounted ballasts shall be located in an accessible, cool, dry location with adequate ventilation. Each ballast shall be labeled to indicate its fixture location.
- 5.4. Recessed compact fluorescent and 2x2 fluorescent luminaires shall be installed such that lamps are aligned in the same relative orientation from one fixture to the next.
- 5.5. Ballast Disposal
- 5.5.A. The designer shall consult with the Department of Environmental Health and Safety (DEHS) for requirements on handling and disposing PCB ballasts.
- 5.5.B. Remove and dispose ballasts that contain PCB per EPA requirements.
- 5.5.C. The contractor shall examine existing ballasts that are to be removed from service. If a ballast does not clearly indicate that it does not contain PCB, it shall be assumed to contain PCB.
- 5.5.D. DEHS shall provide a ballast collection container at or near the project site. Ballasts that contain PCB shall be placed in the ballast collection container as they are removed. The University shall dispose of the container and its contents.

6. Luminaires

6.1. For lensed fluorescent luminaires, the lenses shall be 100% virgin acrylic injection molded prismatic diffusers meeting the ASTM specifications for methacrylate molding compounds D.788-69A. Minimum lens thickness shall be 0.125”.

6.2. Installation

6.2.A. Provide aiming diagrams for luminaires that require the contractor to aim the luminaires. The A/E shall witness the aiming.

6.2.B. Provide details of supports for luminaires on the drawings. Cleaning: All luminaires shall be thoroughly cleaned and clear from dust, paint, construction debris and fingerprints after all other trades are complete, but prior to the date of substantial completion.

7. Commissioning

7.1. The lighting control elements shall be properly set and tested for optimal operation. Commissioning agent shall provide a report for the following systems (as applicable for the project):

- Daylight harvesting
- Occupancy sensors
- Building automated lighting controls
- Dimming Systems
- Emergency relays

7.2. The appropriate University engineering staff shall be invited to attend these sessions.

END OF SECTION

26 52 00 EMERGENCY LIGHTING

1. General

- 1.1. Each building shall be equipped with an egress lighting system as required by applicable code(s).
- 1.2. Provide emergency lighting along the path of egress, including the exterior of a building and ending at a public way (or as approved by Energy Management).
- 1.3. Refer to section 26 09 23 for lighting controls requirements.
- 1.4. **PROHIBITED:** Battery type emergency lighting, without prior approval from Energy Management.
- 1.5. In the event battery backed up emergency lighting is accepted by the University electrical engineering staff, it must conform to the following requirements
 - 1.5.A. Lighting elements shall be LED (light emitting diode) type.
 - 1.5.B. All self-contained battery pack lighting (unit equipment) shall be self-testing. Each unit shall show positive, visual confirmation that the unit is functional and shall show visual indication of a self-test failure.
 - 1.5.C. All central inverter systems shall comply with the applicable requirements of 26 33 53 STATIC UNINTERRUPTIBLE POWER SUPPLY
 - 1.5.D. When the total number of lights on battery backup exceeds 5kVA or 25 individual fixtures, utilize a central lighting inverter instead of individual batteries for each fixture.
 - 1.5.E. For systems smaller than 5kVA or 25 fixtures, perform a total lifetime cost analysis to determine if a central lighting inverter or individual battery backed up fixtures provide the best value to the University.
 - 1.5.F. **PROHIBITED:** Lighting ballasts with integral battery backup. Battery backup of standard lighting fixtures shall be through a central inverter system only.
 - 1.5.G. If battery backed up lighting is approved for exterior lighting, the fixture battery shall be located inside the building. Integral batteries are prohibited for exterior lighting.
- 1.6. Stairwells, lobbies, hallways and entrances shall have ample lighting to allow for night cleaning. Wall mounted ADA compliant fixtures with integral occupancy sensors and dimming ballasts are required for stairwells.

END OF SECTION

26 53 00 EXIT SIGNS

1. General

- 1.1. Exit lights shall be green LEC type signs, or University electrical engineering approved red LED and have stencil face with red or green letters with power consumption of less than 5 watts.
- 1.2. Consider vandal-resistant models for dormitory design.
- 1.3. **PROHIBITED:** Self-contained exit signs powered by a radioactive source (tritium or similar).

END OF SECTION

26 55 00 SPECIAL PURPOSE LIGHTING

1. Elevator Shafts

- 1.1. A continuous strip of lighting shall be installed the entire length of the elevator shaft for maintenance purposes.
- 1.2. Lighting type shall be LED.
- 1.3. Each shaft must have its own lighting.
 - 1.3.A. **PROHIBITED:** Sharing lighting between two shafts.
- 1.4. Shafts that are visible (e.g. glass elevators), may be an exception to this standard and shall be discussed with the University elevator maintenance staff to determine the requirements.

END OF SECTION

26 56 00 EXTERIOR LIGHTING

1. General

- 1.1. **PROHIBITED:** Bollard and underground luminaires in sidewalks and roadway areas.
- 1.2. Refer to the University Exterior Design Standards for fixture types. Verify the historical and non-historical areas for fixture application with the university.
- 1.3. General area and security lighting shall be LED, unless special requirements are needed and submitted for approval.
- 1.4. Lighting in parking lots shall be per the Parking and Transportation Services department standards. Refer to appendices in the Design Standards for Parking Structures for complete information on lighting standards for parking facilities.
- 1.5. Construction Site Lighting: Provide temporary exterior lighting that meet IESNA requirements for sidewalk lighting, around the perimeter fence line of construction sites for the safety of pedestrians traveling to and from adjacent facilities.
- 1.6. Campus security, walkway and street lighting shall comply with the following:
 - 1.6.A. Average to minimum foot-candle ratio: 4 to 1 or less
 - 1.6.B. Average illuminance: 1 foot-candle min.
- 1.7. All other applications shall follow the latest recommendations of the Illuminating Engineering Society (IES).
- 1.8. Fixture Lenses: Historical site and pedestrian light fixtures shall use glass lenses. Street lighting shall use high impact polycarbonate lenses that are ultraviolet stabilized.

2. Poles and Standards

- 2.1. Refer to the University Exterior Design Standards for additional information.
- 2.2. Verify the historical and non-historical areas for fixture application with the university.
- 2.3. The approved fixture for most pedestrian/walkway lighting is the Holophane Washington Fixture
 - 2.3.A. Verify final part numbers with Energy Management
 - 2.3.B. Typical Fixture Part Number:
WAE3 P30 40K MVOLT MS BK GL5 SBR TBK AO PR7 FPD75
 - 2.3.C. Contact Energy Management Electrical Engineering for fixture photometric file.
 - 2.3.D. Specify a Holophane Sitelink pole. Typical Part number
WDA10L4E17P07ABGBK or WDA12L4E17P07ABGBK
- 2.4. Use of fixtures other than type III or type V lighting distribution must be approved by Energy Management.

- 2.5. Parking lots shall use Cree Edge luminaires.
- 2.6. Parking lot light fixture bases shall extend 36" above grade. The bases shall not be painted.
- 2.7. Street Lighting fixtures taller than 14' shall use Cooper Lighting Navion fixtures. Contact Energy Management for acceptable part numbers.
- 2.8. Describe poles in the fixture schedule. Provide complete details for bases on the electrical drawings. Anchor bolts shall be galvanized.
- 2.9. Include required grounding. Provide a copper grounding rod in the concrete base.
- 2.10. Provide in-line fuses that are readily accessible via hand holes in the base of the pole. Fuse holder shall be exterior grade, 600V rated with EPDM rubber jacket.**
- 2.11. Provide UL listed water-tight splices for all splices in light pole bases.
 - 2.11.A. If using silicone filled splices, provide 12" of additional wire, coiled up in the light pole base or handhole.
- 2.12. Provide round concrete bases with chamfered edges. Bases shall extend a minimum of 3 inches above the sidewalk, sod, or mulched landscape.

3. Exterior Lighting Control

- 3.1. Provide a photocell operated lighting contactor with bypass switch for fixture equipment.
 - 3.1.A. **PROHIBITED:** Processor, PLC or any programmable control system or panel.

4. Exterior Lighting Circuits

- 4.1. Strings of more than 4 fixtures shall be provided with two separate power circuits, each feeding alternating fixtures.
 - 4.1.A. Each circuit shall be provided with a dedicated neutral. Sharing neutral wires is prohibited.
- 4.2. Reference 26 05 19 for additional wiring requirements

5. Calculations

- 5.1. The A/E shall submit one (1) copies of computer generated point-by-point calculations to Energy Management for review. Point levels shall be legible and plan to scale. All pertinent calculation parameters shall be indicated and highlighted where non-compliant. Energy Management will provide direction and variance where deemed adequate.
- 5.2. Coordinate the method of calculating the vertical foot-candle requirement for Walkways with the University electrical engineering staff.

END OF SECTION

APPENDIX A – GUIDELINES FOR REMODELS IMPACTING EXISTING EMERGENCY GENERATORS

Background:

The University of Minnesota – Twin Cities Campus frequently remodels spaces with existing optional standby loads connected to the building emergency system. This document is intended to provide guidance for design professionals regarding renovation of these systems. This document is intended for renovations of less than 50% of the building space.

Existing Transfer Switches Supplying Both Emergency and Non-Emergency Loads:

The current edition of the National Electric Code requires loads designated as emergency to be supplied by a separate transfer switch. This emergency transfer switch is not permitted to supply any non-emergency loads.

Many existing U of MN buildings were constructed prior to this requirement coming in to effect.

Any existing transfer switches supplying a combination of emergency and non-emergency loads shall be considered emergency transfer switches. No new non-emergency loads may be connected to these transfer switches.

Emergency loads may be connected to existing transfer switches supplying both emergency and non-emergency loads.

Renovation of Space Using Minnesota Conservation Code for Existing Buildings:

Alteration – Level 1

Existing receptacles in the space, supplied by an emergency transfer switch are not required to be removed from the emergency transfer switch.

The existing receptacles may not be relocated or altered. The associated circuits may not be extended.

Any modifications to the receptacles or associated circuits requires they be removed from the emergency transfer switch.

Alteration – Level 2

Any receptacles and associated circuits within the project area, supplied by an emergency transfer switch, must be removed from the emergency transfer switch. Any non-emergency loads being connected to the building generator system must be fully compliant with the current edition of all applicable codes.

Renovation of Space Using Minnesota Building Code:

Comply with requirements of Minnesota Conservation Code for Existing Buildings, Alteration – Level 2.

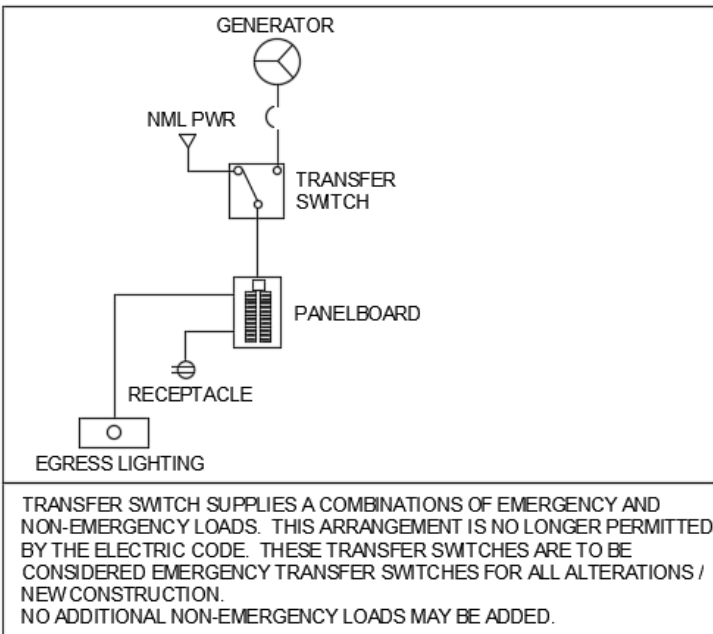

Figure A1: Schematic of Transfer Switch Supplying Both Emergency and Non-Emergency Loads

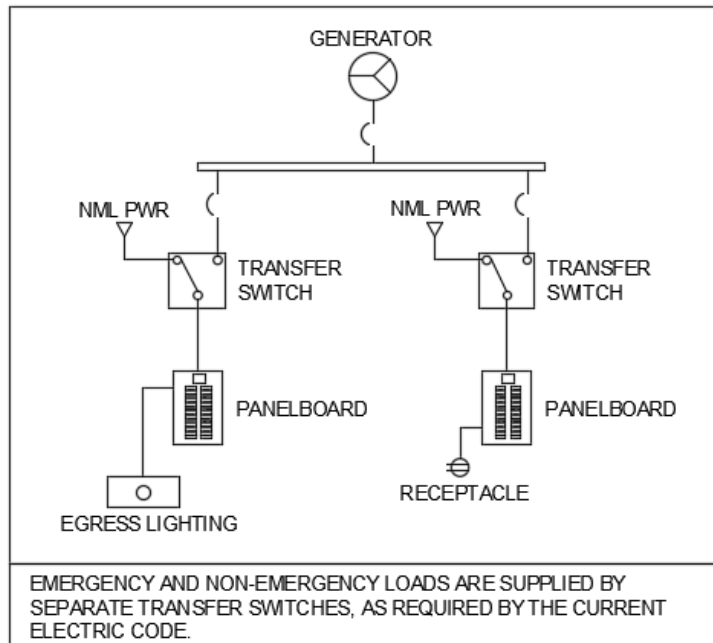

Figure A2: Schematic of Separate Transfer Switches for Emergency and Non-Emergency Loads

Additional Requirements for Connections of New Loads to Existing Generator Systems:

Total Connected Generator Load Calculation:

The total connected generator load must be determined by the design professional before and new loads can be added to an existing generator system.

Most generator systems on campus do not have existing load calculations available.

Use of meter data to determine existing generator load must comply with NEC article 220. Load readings from monthly generator testing do not meet these requirements and may not be used to determine connected generator load.

When generator connected load can not be determined, or if calculations show it to be at/beyond rated capacity, new loads must be provided with an automatic load shed system. Emergency and legally required standby loads may not be connected to a load shed system.

Emergency loads may be connected to the existing generator system if the design professional can demonstrate that the total connected generator load will not increase. For example, if egress lighting in an area will be converted from fluorescent lighting to LED, resulting in an overall load decrease, no further load calculations are required.

Selective Coordination:

New emergency load panelboards must be selectively coordinated. Emergency panels do not need to coordinate with existing upstream protective devices, where selective coordination is not possible.

New non-emergency transfer switches must be installed in a way that provides selective coordination with the emergency system.

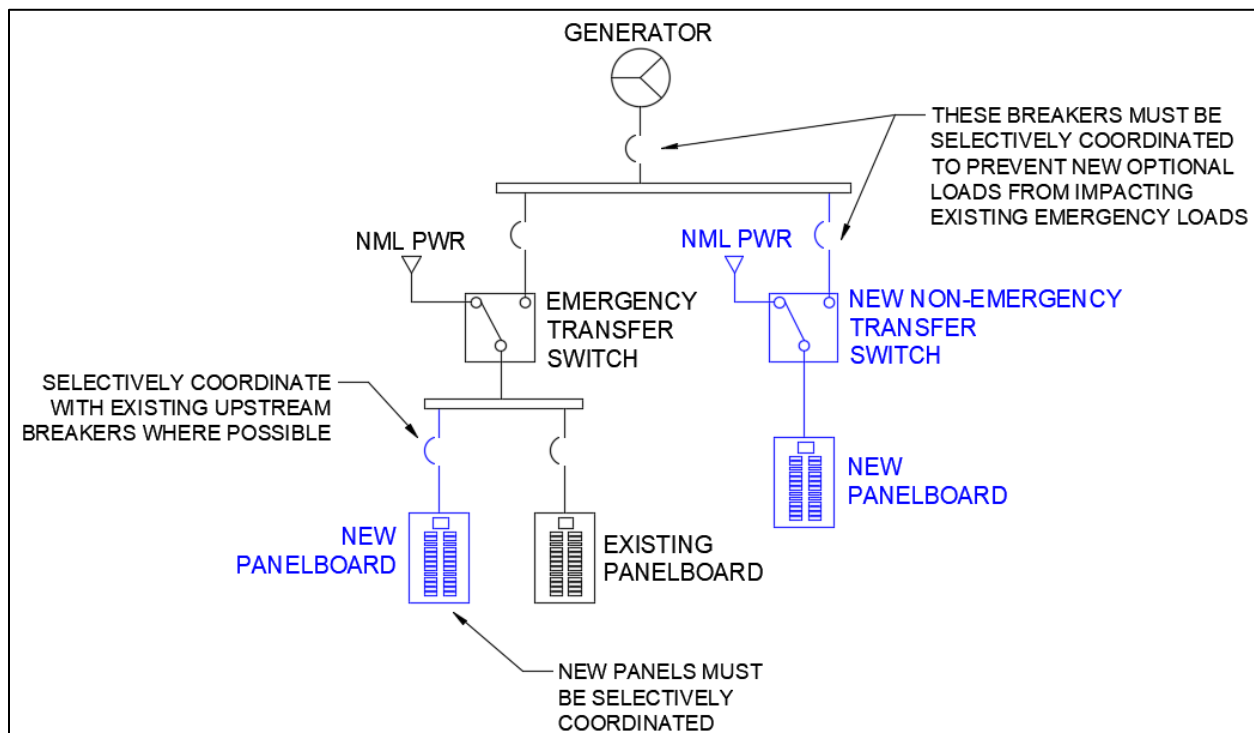

Figure A3: Selective Coordination Requirements

END OF SECTION

DIVISION 26 – LIST OF FIGURES

1. Figure 1A - Typical Redundant Primary and Secondary Service Oneline
2. Figure 1B – Typical Single Xfmr Primary and Secondary Service Oneline
3. Figure 1C – Typical Single Xfmr – Padmount Service – Primary and Secondary Service Oneline
4. Figure 2A – Typical Service Meter AC Wiring Schematic
5. Figure 2B – Typical Service Meter Control Wiring Schematic
6. Figure 2C – Typical 480V Deduct Meter AC Wiring Schematic
7. Figure 2D – Typical 208V Deduct Meter AC Wiring Schematic
8. Figure 2E – Typical Metering 1,000V or Greater – AC Schematic
9. Figure 3 – Typical Elect Manhole Details
10. Figure 4A – Duct Bank Section Profile – Side Detail
11. Figure 4B – Duct Bank Cross Section Details
12. Figure 4C – Duct Bank Wall Entry Detail
13. Figure 5 – Typical Points Monitored By SCADA and BAS
14. Figure 6 – Typical Exterior Lighting Base Detail
15. Figure 7 – Sample Arc Flash Hazard Label Guidelines
16. Figure 8 – UPS Alternate Source Connection Schematic
17. Figure 9 – Alternate Source Connection Details
18. Figure 10 – Typical Electric Vault Ground Grid Details

DIVISION 26 - FIGURE 1A

TYPICAL REDUNDANT PRIMARY & SECONDARY SERVICE
ONE LINE

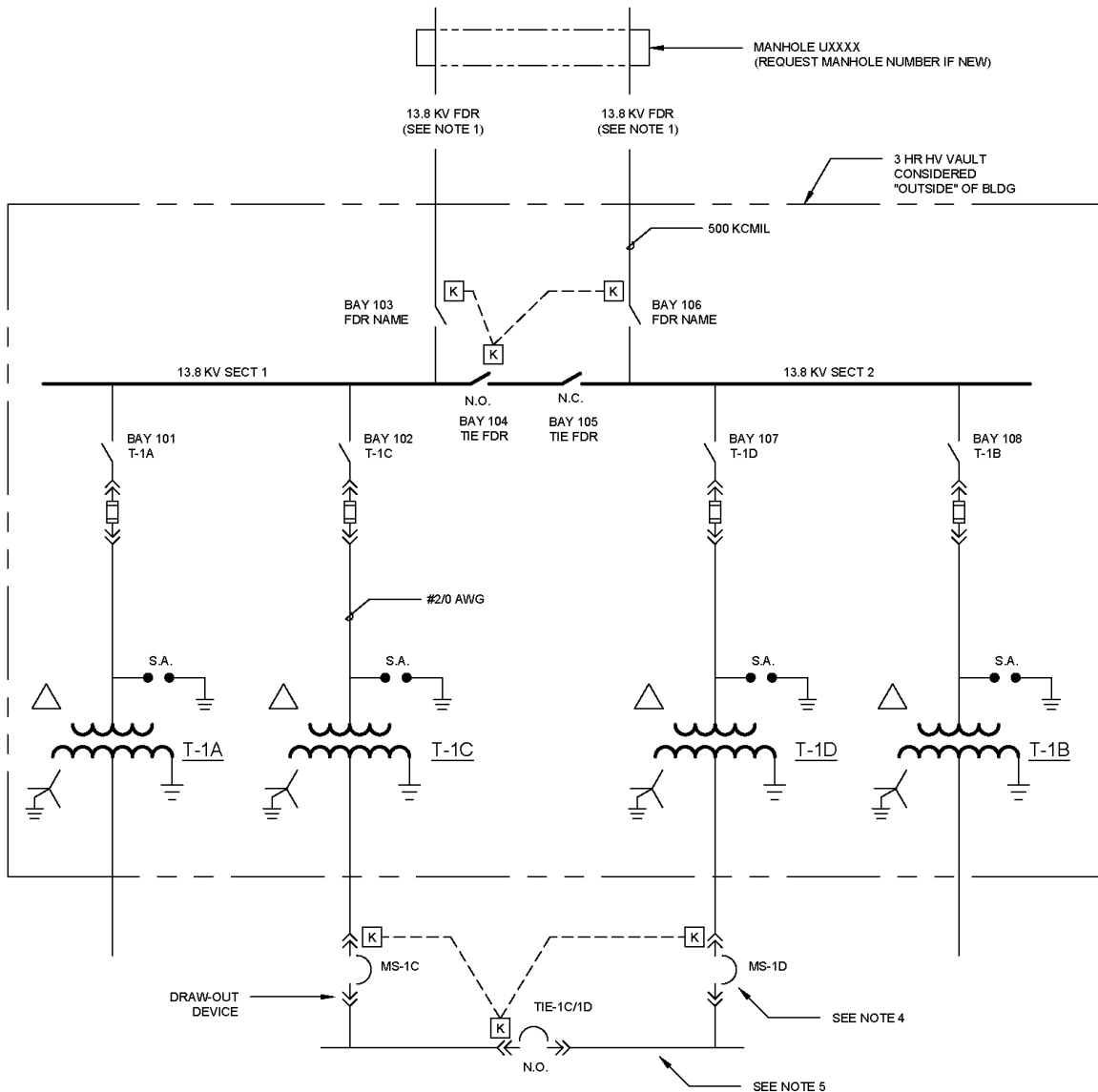

NOTES:

1. INCLUDE 13.8 KV FEEDER NAMES ON DWG. REQUEST NAMES FROM UNIVERSITY ELECTRICAL ENGINEERING STAFF.
2. ALL 13.8 KV FUSES SHALL BE EXPULSION TYPE AS MANUFACTURED BY S&C ELECTRIC. MAXIMUM FUSE SIZE SHALL NOT EXCEED 125E.
3. MAXIMUM TRANSFORMER SIZE IS 1500 KVA, NAN.
4. THE MAIN SECONDARY DISCONNECT IS CONSIDERED THE SERVICE ENTRANCE POINT TO THE BUILDING.
5. PROVIDE SPD WITH DISCONNECT LOAD SIDE OF EACH SERVICE DISCONNECT.

REVISION 3
06-05-17

DIVISION 26 - FIGURE 1B

**TYPICAL SINGLE XFMR PRIMARY & SECONDARY SERVICE
ONE LINE**

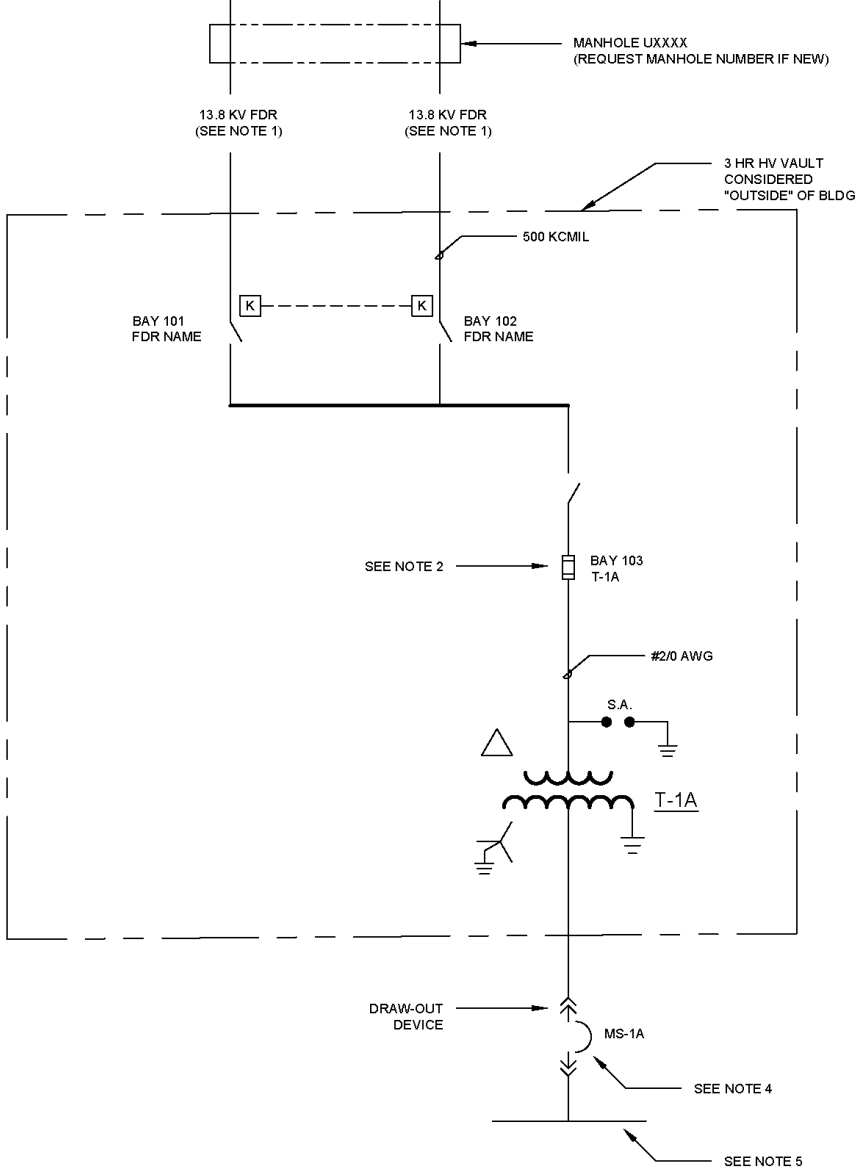

- NOTES:**
1. INCLUDE 13.8 KV FEEDER NAMES ON DWG. REQUEST NAMES FROM UNIVERSITY ELECTRICAL ENGINEERING STAFF.
 2. ALL 13.8 KV FUSES SHALL BE EXPULSION TYPE AS MANUFACTURED BY S&C ELECTRIC. MAXIMUM FUSE SIZE SHALL NOT EXCEED 125E.
 3. MAXIMUM TRANSFORMER SIZE IS 1500 KVA, NAN.
 4. THE MAIN SECONDARY DISCONNECT IS CONSIDERED THE SERVICE ENTRANCE POINT TO THE BUILDING.
 5. PROVIDE SPD WITH DISCONNECT LOAD SIDE OF EACH SERVICE DISCONNECT.

REVISION 4
05-09-19

DIVISION 26 - FIGURE 1C

TYPICAL SINGLE XFMR - PADMOUNT SERVICE - PRIMARY & SECONDARY SERVICE
ONE LINE

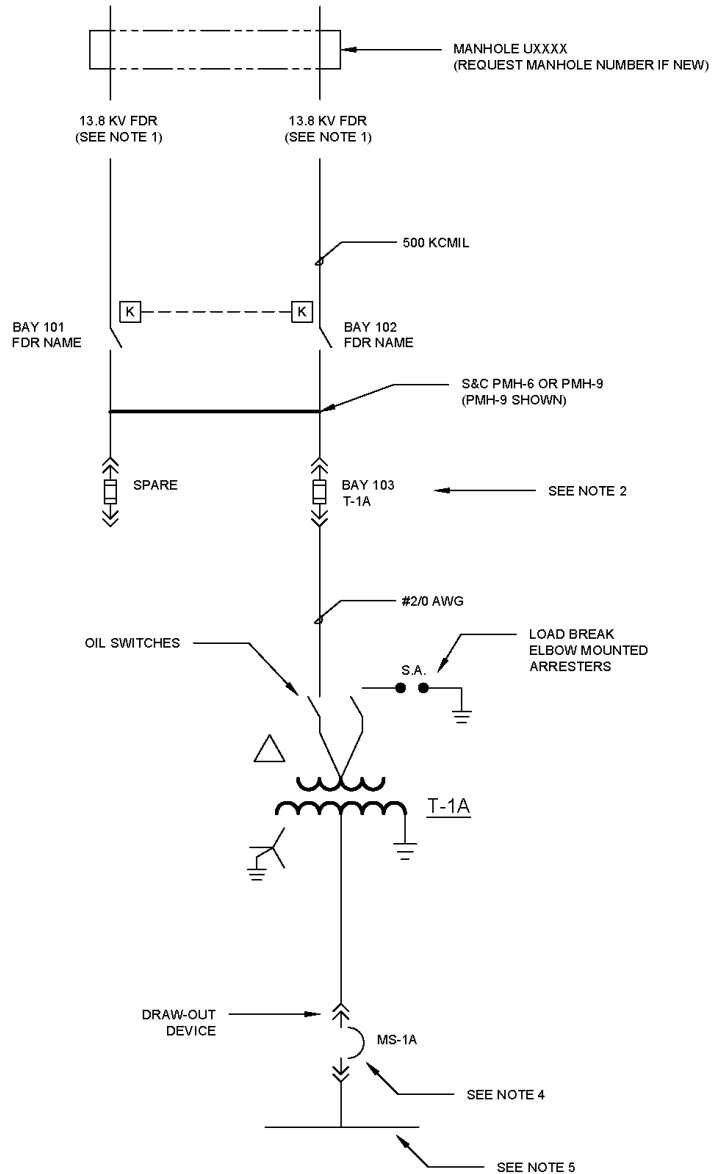

NOTES:

1. INCLUDE 13.8 KV FEEDER NAMES ON DWG. REQUEST NAMES FROM UNIVERSITY ELECTRICAL ENGINEERING STAFF.
2. ALL 13.8 KV FUSES SHALL BE EXPULSION TYPE AS MANUFACTURED BY S&C ELECTRIC. MAXIMUM FUSE SIZE SHALL NOT EXCEED 125E.
3. MAXIMUM TRANSFORMER SIZE IS 1500 KVA, NAN.
4. THE MAIN SECONDARY DISCONNECT IS CONSIDERED THE SERVICE ENTRANCE POINT TO THE BUILDING.
5. PROVIDE SPD WITH DISCONNECT LOAD SIDE OF EACH SERVICE DISCONNECT.

REVISION 3
06-05-17

DIVISION 26 - FIGURE 2A

TYPICAL SERVICE METER AC WIRING SCHEMATIC

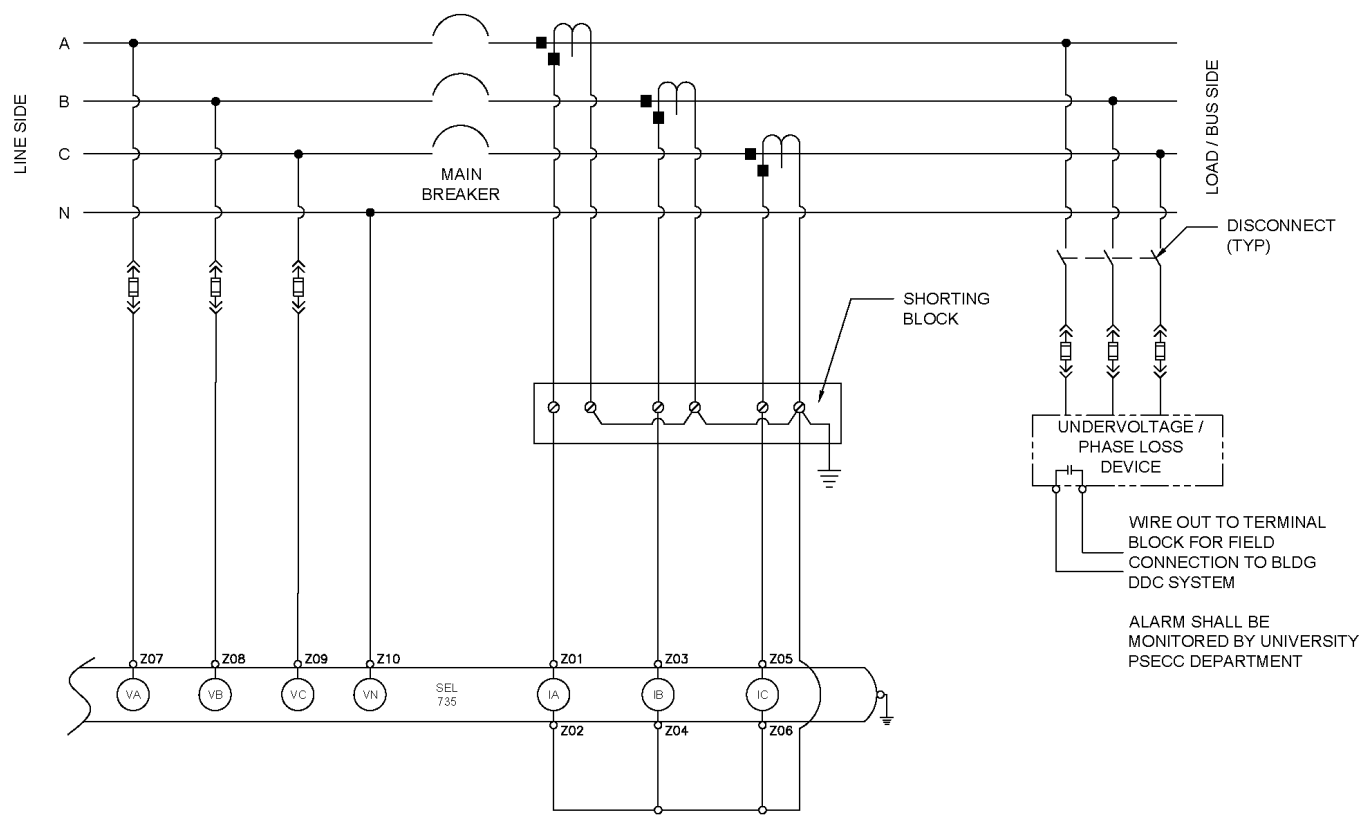

NOTES:

1. CURRENT TRANSFORMER WIRING SHALL BE A MINIMUM OF #12 AWG, TYPE SIS SWITCHBOARD WIRE. ALL OTHER WIRING SHALL BE A MINIMUM OF #14 AWG, TYPE SIS.

05-09-19

DIVISION 26 - FIGURE 2B

TYPICAL SERVICE METER CONTROL WIRING SCHEMATIC

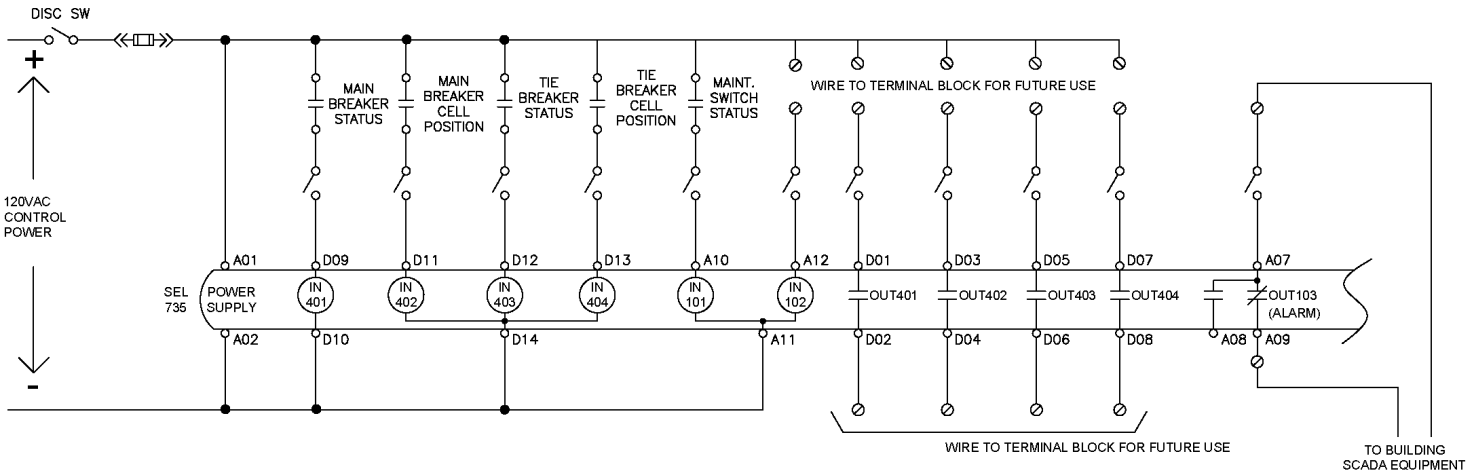

- NOTES:**
1. ALL WIRING SHALL BE A MINIMUM OF #14 AWG, TYPE SIS SWITCHBOARD WIRE.
 2. TIE BREAKER STATUS POINTS ONLY NEED TO BE WIRED TO ONE OF THE TWO MAIN BREAKER METERS.

REVISION 3
05-09-19

DIVISION 26 - FIGURE 2C

TYPICAL 480V DEDUCT METER AC WIRING SCHEMATIC

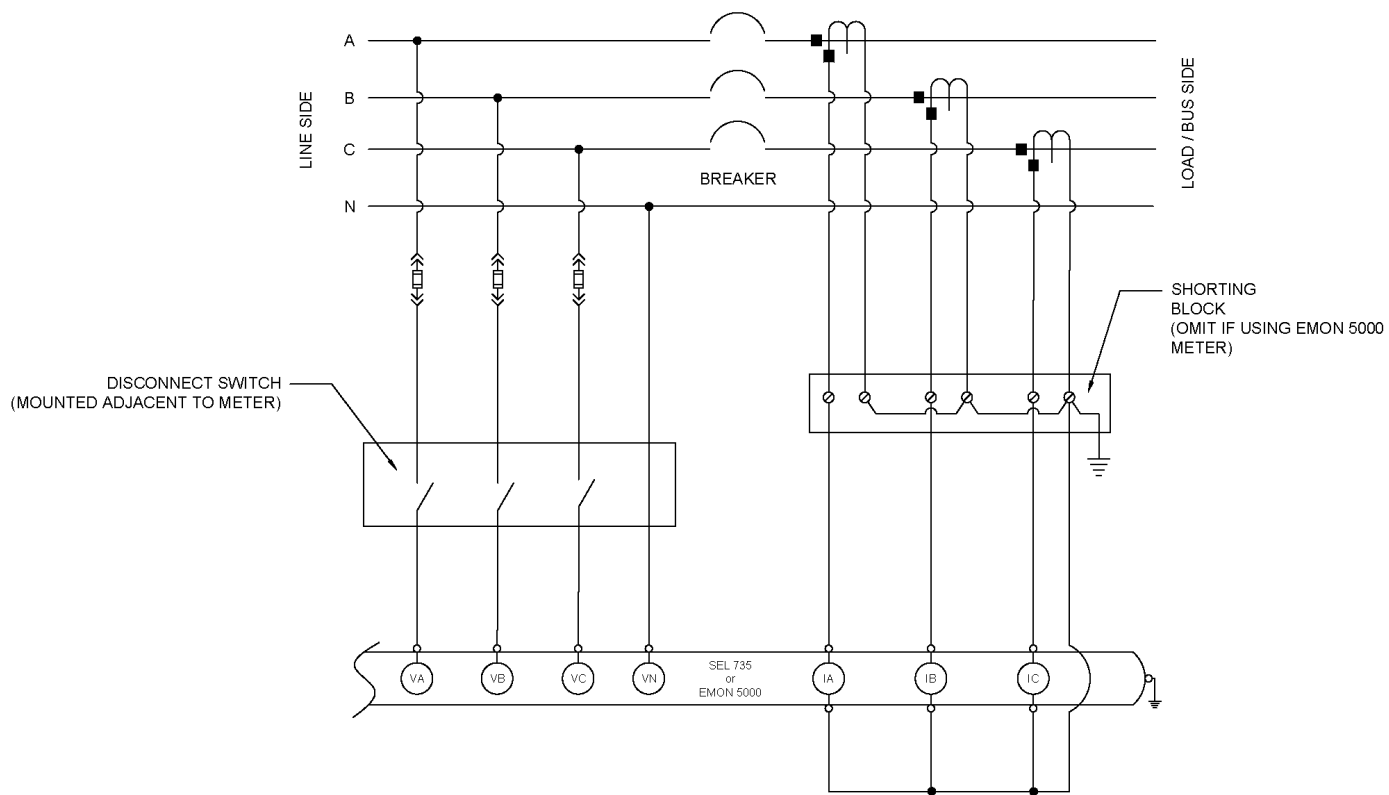

NOTES:

1. CURRENT TRANSFORMER WIRING SHALL BE A MINIMUM OF #12 AWG, TYPE SIS SWITCHBOARD WIRE. ALL OTHER WIRING SHALL BE A MINIMUM OF #14 AWG, TYPE SIS.

REVISION 5
07-26-22

DIVISION 26 - FIGURE 2D

TYPICAL 208V DEDUCT METER AC WIRING SCHEMATIC

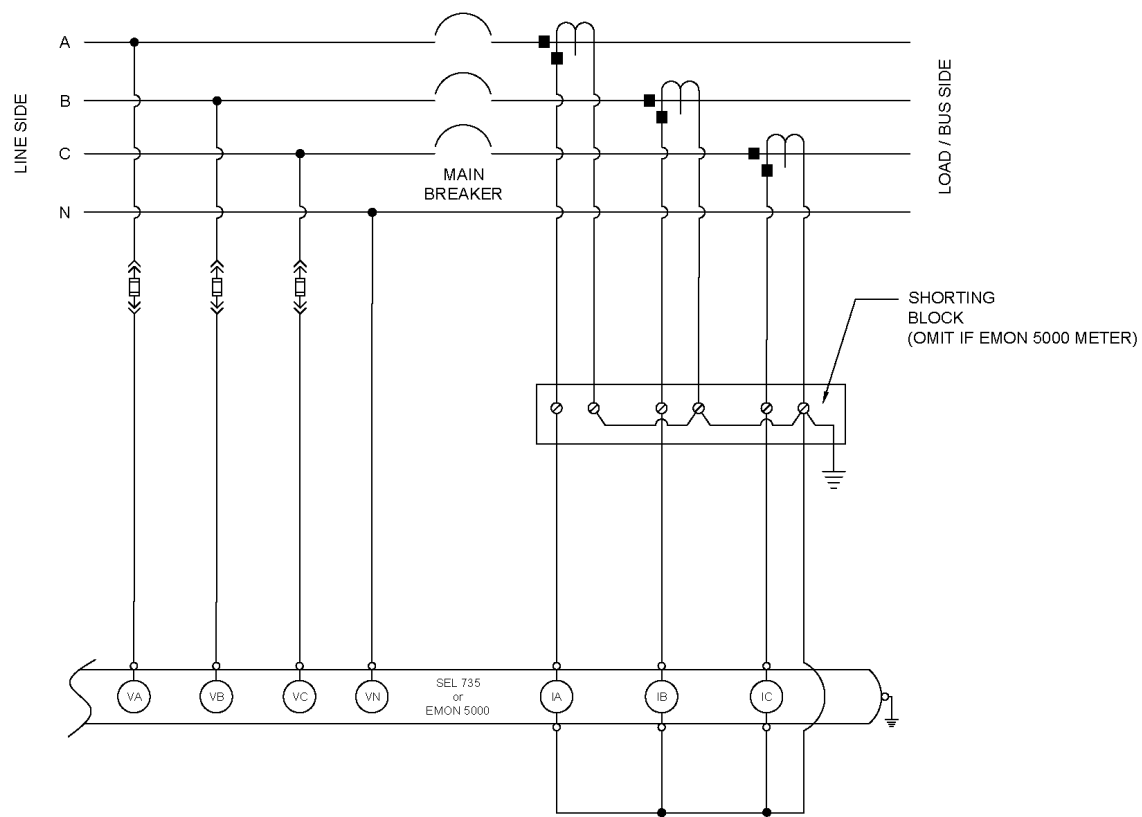

- NOTES:**
1. CURRENT TRANSFORMER WIRING SHALL BE A MINIMUM OF #12 AWG, TYPE SIS SWITCHBOARD WIRE. ALL OTHER WIRING SHALL BE A MINIMUM OF #14 AWG, TYPE SIS.

REVISION 4
05-09-19

DIVISION 26 - FIGURE 2E

METERING - 1,000V OR GREATER - AC WIRING SCHEMATIC

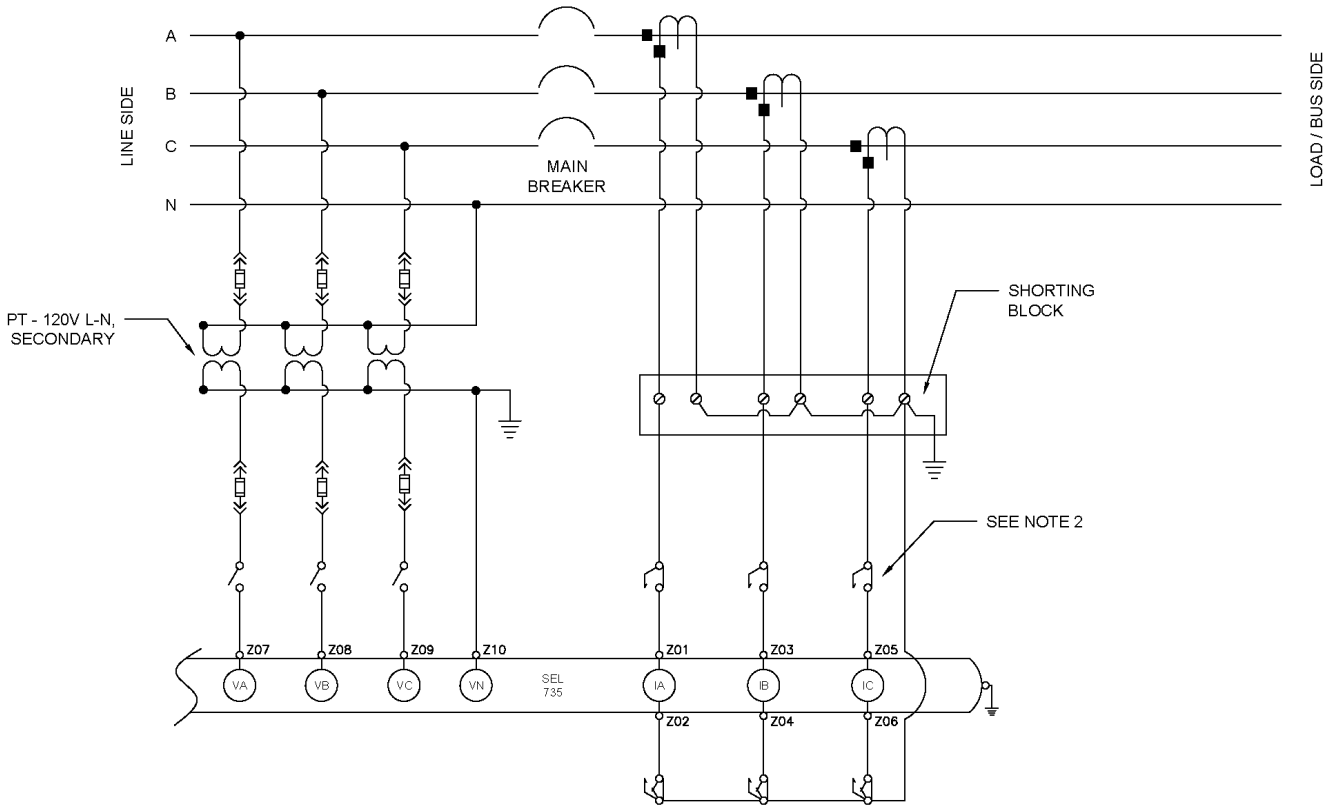

NOTES:

1. CURRENT TRANSFORMER WIRING SHALL BE A MINIMUM OF #12 AWG, TYPE SIS SWITCHBOARD WIRE. ALL OTHER WIRING SHALL BE A MINIMUM OF #14 AWG, TYPE SIS.
2. TEST SWITCH SHALL BE ABB FT-1 STYLE # C129A514G01

REVISION 1
05/09/19

DIVISION 26 - FIGURE 3
TYPICAL ELECT MANHOLE DETAILS

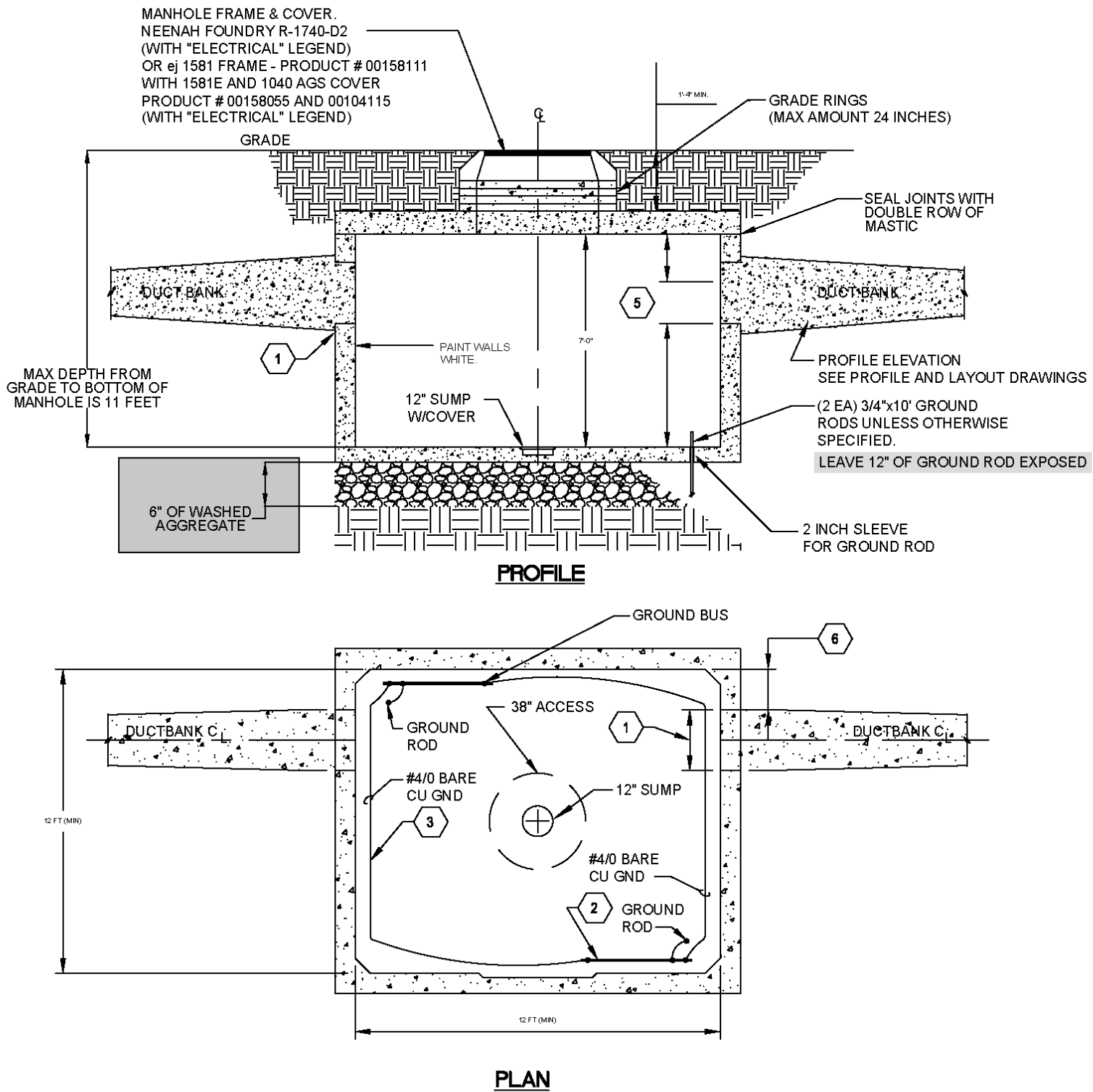

DETAIL KEYED NOTES:

- 1 REFER TO DUCT BANK DETAIL DRAWING FOR DUCT BANK ENTRANCE INTO A MANHOLE.
- 2 FURNISH AND INSTALL TWO RIGID 1/4"x4"x24" GROUND BUSES IN EACH MANHOLE. EACH GROUND BUS SHALL HAVE PRE-DRILLED 1/2 INCH HOLES WITH NEMA 2-HOLE SPACING. BOND GROUND BUS TO GROUND ROD AND TO EACH OTHER WITH A BARE #4/0 AWG COPPER WIRE. GROUND BUS MOUNTING HEIGHT: 12" FROM CEILING.
- 3 SUPPORT BARE #4/0 AWG COPPER WIRE WITH A MAXIMUM SPACING OF 24". WIRE SUPPORTS SHALL BE GALVANIZED STEEL WITH STAINLESS STEEL HARDWARE.
- 4 TWO PIECE 'CLAM' STYLE MANHOLES PROHIBITED
- 5 24" MIN. BETWEEN TOP OF MANHOLE AND TOP OF HIGHEST DUCTBANK BARREL
12" MIN. BETWEEN THE BOTTOM OF MANHOLE AND BOTTOM OF LOWEST DUCTBANK BARREL
- 6 24" MINIMUM BETWEEN WALL OF MANHOLE AND CLOSEST DUCTBANK BARREL

REVISION 5
07-26-22

DIVISION 26 - FIGURE 4A
DUCT BANK SECTION PROFILE - SIDE DETAIL

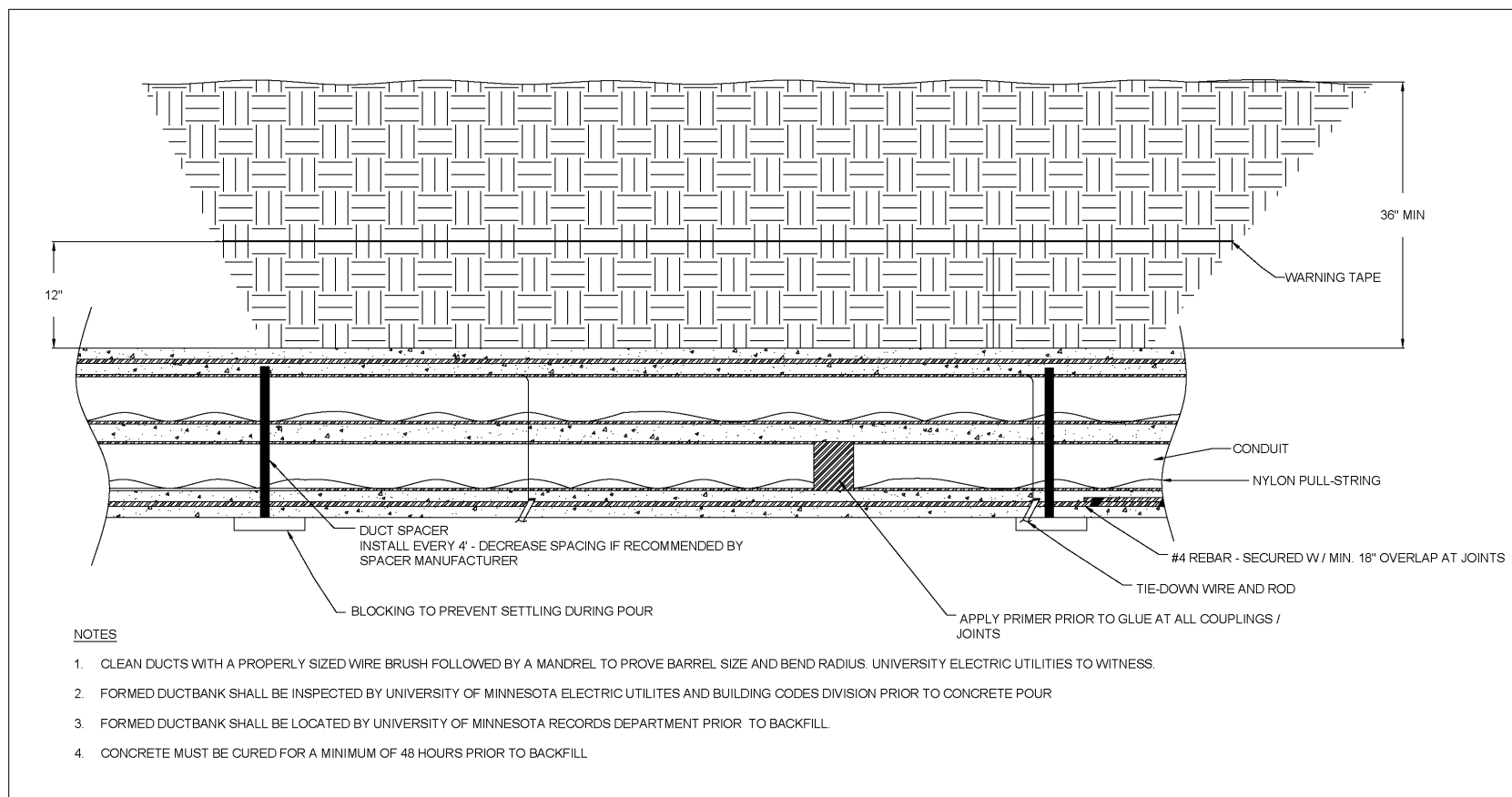

REVISION 2
09-06-17

DIVISION 26 - FIGURE 4B
DUCT BANK CROSS SECTION DETAILS

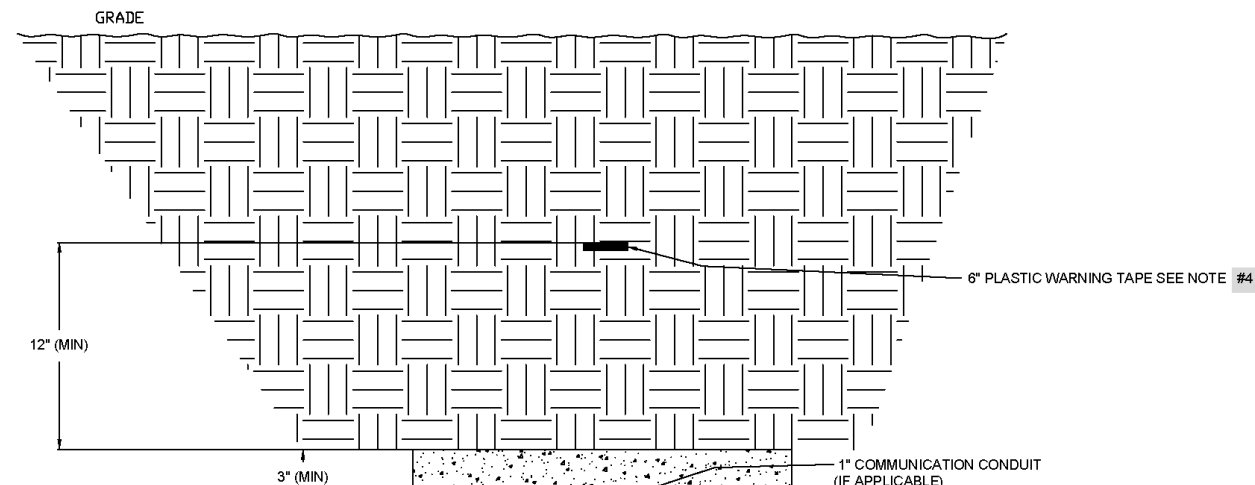

NOTES

1. DUCT BANK SHALL BE ENCASED IN CONCRETE WITH AT LEAST THREE INCHES OF CONCRETE AT THE TOP, BOTTOM AND SIDES. THIS IS A TYPICAL EXAMPLE OF DUCT BANK CONSTRUCTION.
2. WHEN PLACING CONCRETE AROUND CONDUITS ADJUST THE DELIVERY CHUTE SO THE FALL OF THE CONCRETE INTO THE TRENCH IS MINIMAL. POUR THE CONCRETE SLOWLY AND DISTRIBUTE IT EVENLY SO AS NOT TO DISLODGE THE SPACERS.
3. CONCRETE ENVELOPE SHALL BE POURED IN FORM. DO NOT USE THE SIDES OF THE TRENCH TO FORM THE VERTICAL WALLS UNLESS APPROVED BY ENGINEER.
4. PLASTIC WARNING TAPE SHALL BE "EXTRA STRETCH" 6" WIDE AS MANUFACTURED BY TERRA-TAPE, DIVISION OF REEF INDUSTRIES OR APPROVED EQUAL. COLOR CODE SHALL BE AS FOLLOWS: RED-ELECTRIC, ORANGE-COMMUNICATIONS, IMPRINTED TEXT SHALL IDENTIFY DUCT BANK SERVICE. UTILIZE NO-DETECTABLE TAPE FOR ELECTRIC DUCTS AND METALLIZED DETECTABLE TAPE FOR COMMUNICATION DUCTS.
5. DUCTS SHALL BE 5" SCHEDULE 40 PVC
6. WHERE APPROVED, 1X4 DUCT BANKS SHALL USE 5" RGS CONDUIT.

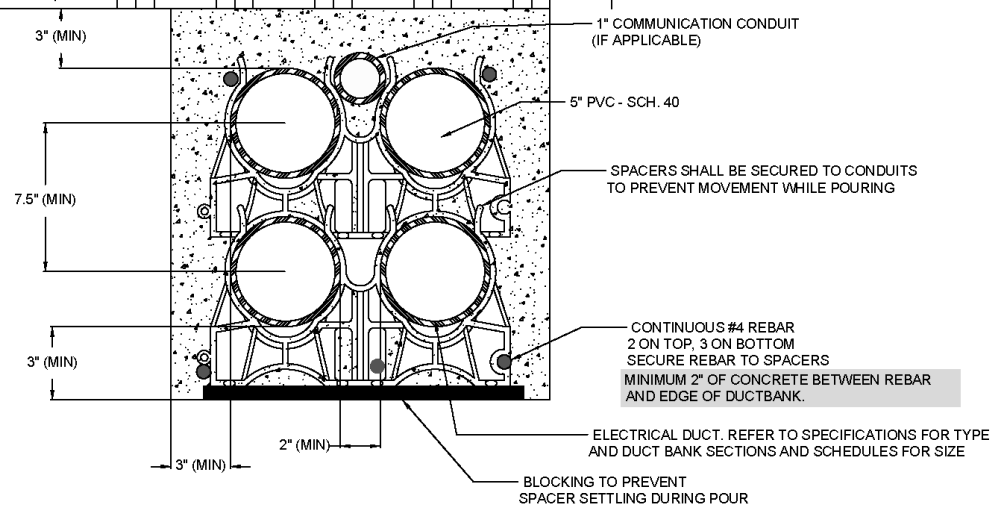

4 BARREL DUCT BANK

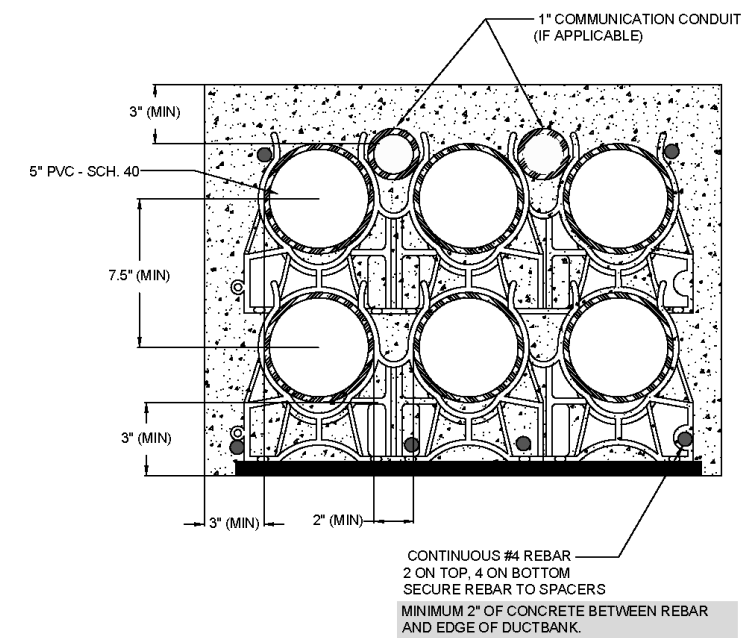

6 BARREL DUCT BANK

REVISION 3
08-26-21

DIVISION 26 - FIGURE 4C
DUCT BANK WALL ENTRY DETAIL

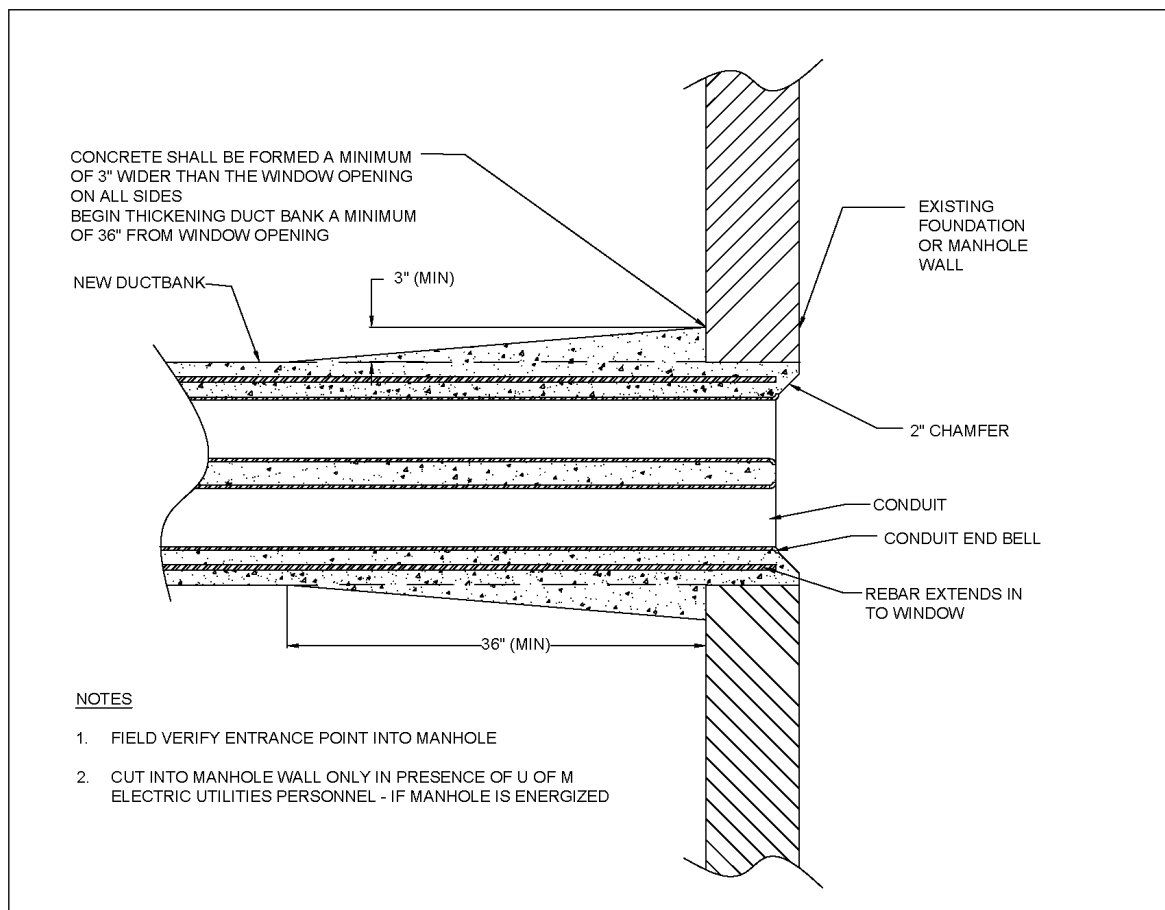

REVISION 2
09-06-17

DIVISION 26 - FIGURE 5 TYPICAL POINTS MONITORED BY SCADA AND BAS

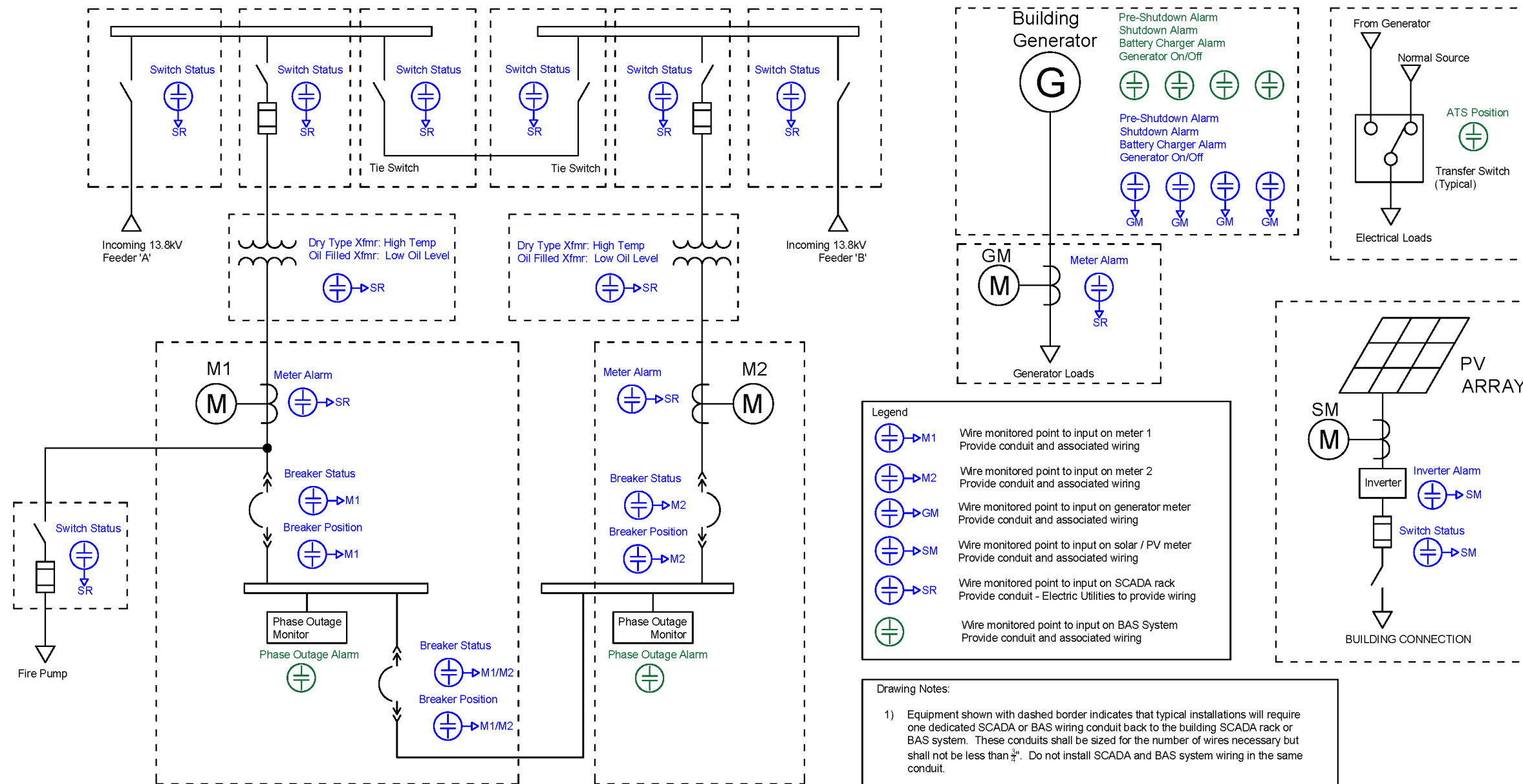

REVISION 3
03-29-19

DIVISION 26 - FIGURE 6
TYPICAL EXTERIOR LIGHTING BASE DETAIL

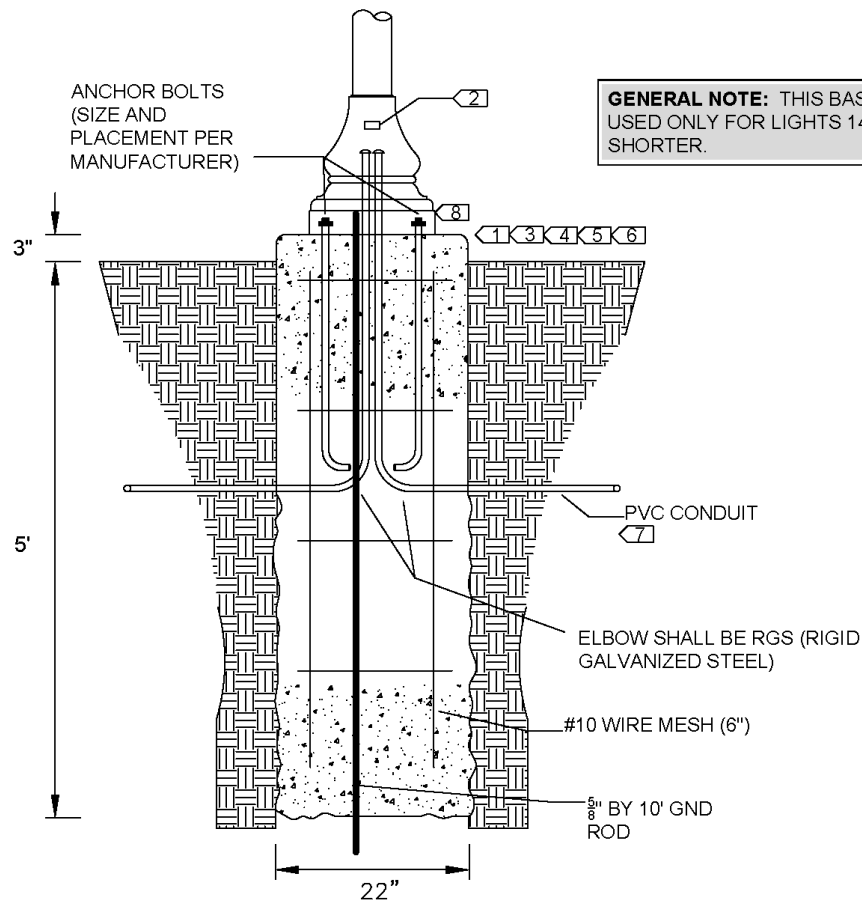

GENERAL NOTE: THIS BASE IS TO BE USED ONLY FOR LIGHTS 14' TALL OR SHORTER.

KEY NOTES

- | | |
|--|--|
| <p>1 TOOLED RADIUS AND HAND RUBBED CONCRETE FINISH ABOVE GRADE.</p> <p>2 FURNISH AND INSTALL INLINE FUSE.</p> <p>3 CONTRACTOR SHALL REMOVE EXPOSED SONOTUBE ONCE THE CONCRETE HAS CURED.</p> <p>4 CONCRETE SHALL BE 4000 PSI, 28 DAY AND AIR ENTRAINED 5.5 TO 6%</p> | <p>5 BASES SHALL BE ROUND. SQUARE BASES ARE PROHIBITED</p> <p>6 BASE SHALL EXTEND 3" ABOVE GRADE / SIDEWALK</p> <p>7 CONDUIT SHALL BE 1-1/4" MIN.</p> <p>8 THE POLE MUST REST DIRECTLY ON THE LIGHT BASE OR GROUTED IN PLACE AFTER INSTALLATION. POLES MUST NOT REST ON LEVELING NUTS.</p> |
|--|--|

REVISION 3
08-26-21

DIVISION 26 - FIGURE 7

SAMPLE ARC FLASH HAZARD LABEL GUIDELINES

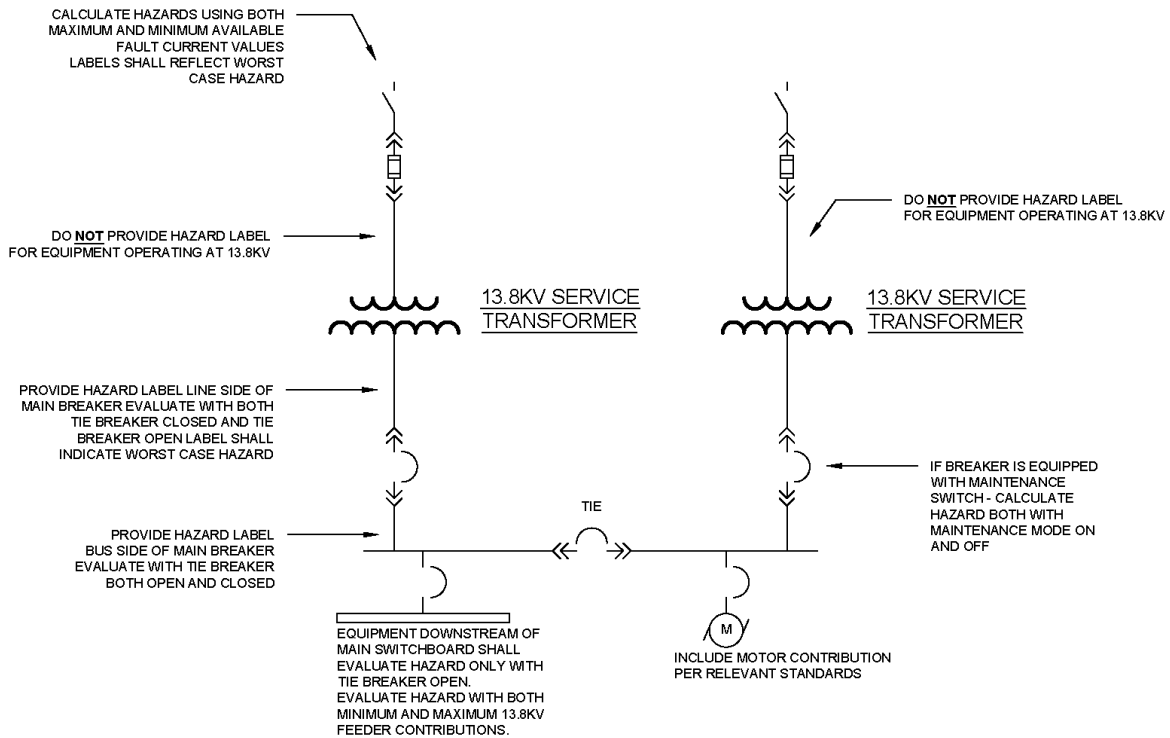

REVISION 1
01-07-19

DIVISION 26 - FIGURE 8

UPS ALTERNATE SOURCE CONNECTION SCHEMATIC

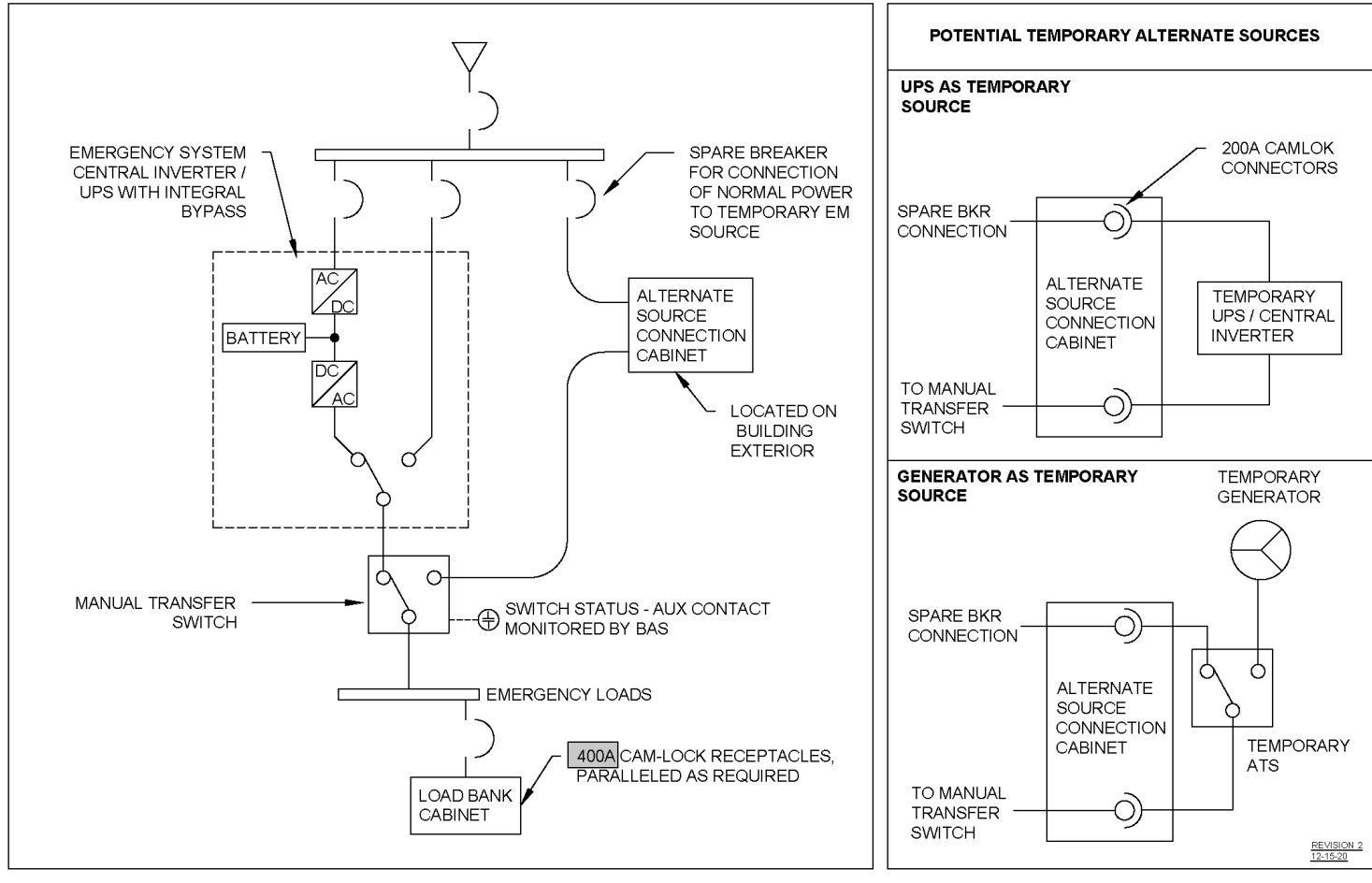

DIVISION 26 - FIGURE 9

ALTERNATE EMERGENCY SOURCE CONNECTION DETAILS

TO PORTABLE GENERATOR CONNECTION CABINET

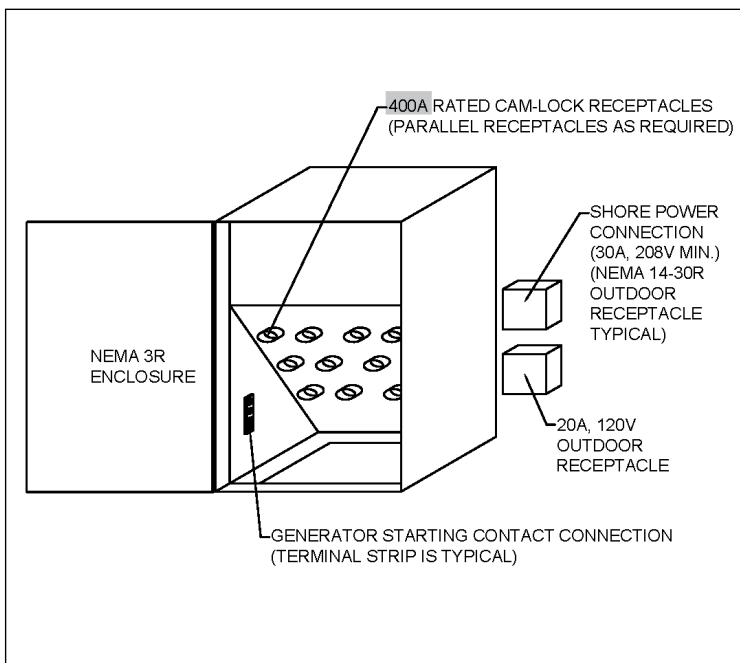

PORTABLE GENERATOR STARTING CONTACT SELECTOR SWITCH DETAIL

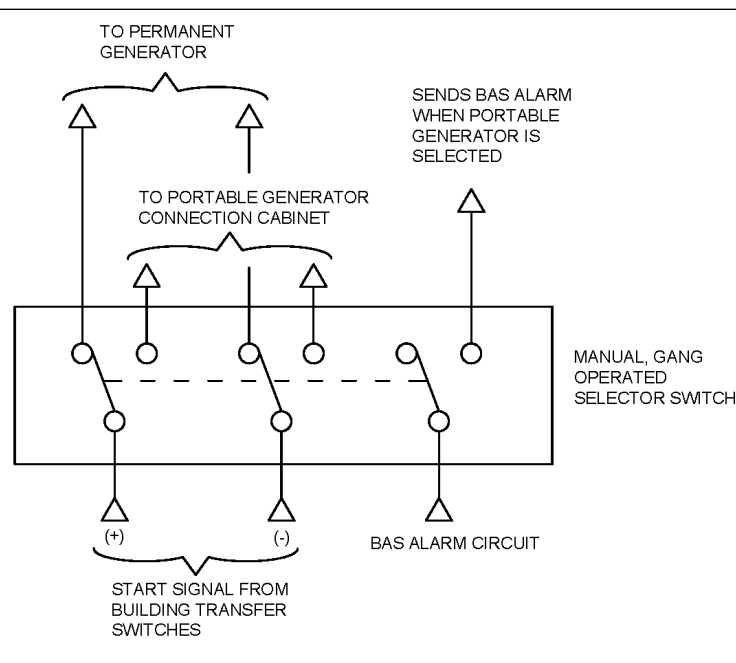

REVISION 2
12-15-20

DIVISION 26 - FIGURE 10
TYPICAL ELECTRIC VAULT GROUND GRID DETAIL

NOTE:
THIS DRAWING IS DIAGRAMMATIC ONLY.
FINAL LAYOUT TO BE DETERMINED BY A/E
BASED ON AVAILABLE SPACE AND ACTUAL VAULT DIMENSIONS

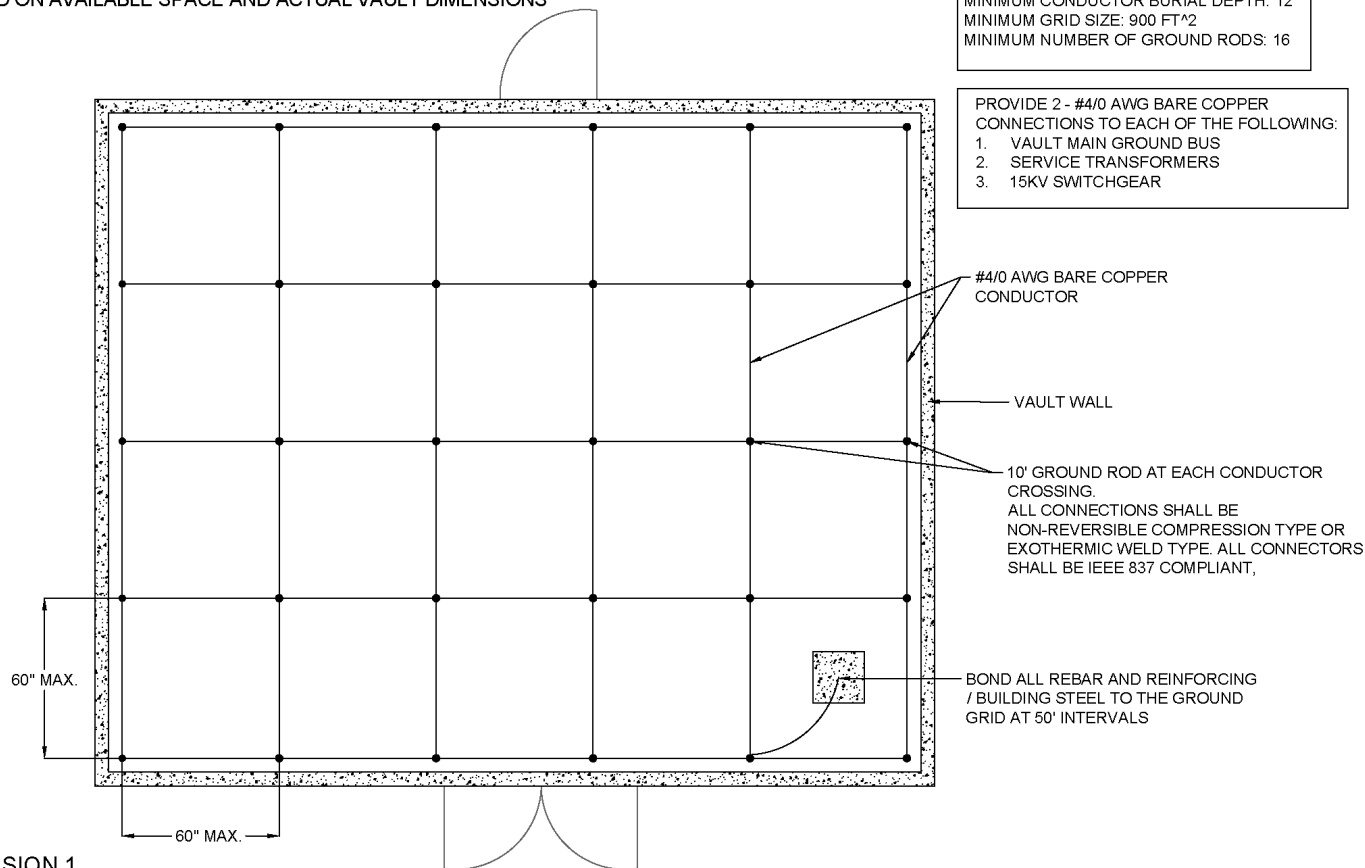

REVISION 1
11-30-21

END OF SECTION